

Owner's Manual



Vacuum Cleaner

Model 116.31722
116.31732



CAUTION:

Read and follow all
safety and operating
instructions before first
use of this product.

Sears, Roebuck and Co., Hoffman Estates, IL 60179 U.S.A.
www.sears.com

PART NO. C01ZBFE10U00-8191585

Printed in U.S.A.

TABLE OF CONTENTS

Before Using Your New Vacuum	2	Vacuum Cleaner Care	13
Kenmore Vacuum Cleaner Warranty	2	Vacuum Storage	13
Important Safety Instructions	3	Cleaning Exterior and Attachments	13
Parts and Features	4	Dust Bin Cleaning	14
Assembly Instructions	5-6	Filter Changing/Cleaning	15-16
Operating Instructions	6	Belt Changing and Agitator Cleaning	17-19
Pile Height Selection and Setting	7	Clog Removal	20
Carpet/Bare Floor Selector	7	Light Bulb Changing	21
Releasing the Handle	8	Agitator Servicing	22
ON/OFF Switch	8	Agitator Assembly	22
Attachments	8-10	Troubleshooting	23
Attachment Use Chart	10	Requesting Assistance Or Service	24
Vacuuming Tips	11		
Performance Features	11-12		

BEFORE USING YOUR NEW VACUUM

Please read this guide. It will help you assemble and operate your new Kenmore vacuum in the safest and most effective way.

For more information about the care and operation, call your nearest Sears store. You will need the complete model and serial numbers when requesting information. Your vacuum's model and serial numbers are located on the Model and Serial Number Plate.

Use the space below to record the model number and serial number of your new Kenmore vacuum.

Model No. _____

Serial No. _____

Date of Purchase _____

Keep this book and your sales check (receipt) in a safe place for future reference.

KENMORE VACUUM CLEANER WARRANTY

FULL ONE-YEAR WARRANTY

When used for private household purposes, if within one year from the date of purchase, this vacuum cleaner fails due to a defect in material or workmanship, **RETURN IT TO THE NEAREST SEARS SERVICE CENTER/DEPARTMENT IN THE UNITED STATES**, and Sears will repair it free of charge.

This warranty gives you specific legal rights, and you may also have other rights which vary from state to state.

SEARS, ROEBUCK AND CO., D/817 WA, Hoffman Estates, IL 60179

IMPORTANT SAFETY INSTRUCTIONS



WARNING

Your safety is important to us. To reduce the risk of fire, electrical shock, injury to persons or damage when using your vacuum cleaner, follow basic safety precautions including the following:

Read this manual before assembling or using your vacuum cleaner.

Use your cleaner only as described in this manual. Use only with Sears recommended attachments.

To reduce the risk of electrical shock – Do not use outdoors or on wet surfaces.

Disconnect electrical supply before any servicing or cleaning. Failure to do so could result in electrical shock or personal injury.

Always turn cleaner off before unplugging.

Do not unplug by pulling on cord. To unplug, grasp the plug, not the cord.

Do not use with damaged cord or plug. If cleaner is not working as it should, has been dropped, damaged, left outdoors, or dropped into water, return it to a Sears Service Center/Department.

Do not pull or carry by cord, use cord as a handle, close door on cord, or pull cord around sharp edges or corners. Do not run cleaner over cord. Keep cord away from heated surfaces.

Do not leave cleaner when plugged in. Unplug from outlet when not in use and before servicing.

Do not allow to be used as a toy. Close attention is necessary when used by or near children.

Do not handle plug or cleaner with wet hands.

Do not put any objects into openings.

Do not use with any opening blocked; keep free of dust, lint, hair and anything that may reduce air flow.

Keep hair, loose clothing, fingers, and all parts of body away from openings and moving parts.

Do not use cleaner without dust bin and/or filters in place.

Always clean the dust bin after vacuuming carpet cleaners or freshener, powders and fine dust. These products clog the filters, reduce airflow and can cause damage to the cleaner. Failure to clean the dust bin could cause permanent damage to the cleaner.

Do not use the cleaner to pick up sharp hard objects, small toys, pins, paper clips, etc. They may damage the cleaner or dust bin.

Do not pick up anything that is burning or smoking, such as cigarettes, matches, or hot ashes.

Do not use cleaner to pick up flammable or combustible liquids (gasoline, cleaning fluids, perfumes, etc.), or use in areas where they may be present. The fumes from these substances can create a fire hazard or explosion.

Use extra care when cleaning on stairs. Do not put on chairs, tables, etc. Keep on floor.

You are responsible for making sure that your vacuum cleaner is not used by anyone unable to operate it properly.

SAVE THESE INSTRUCTIONS

Proper assembly and safe use of your vacuum cleaner are your responsibilities. Your cleaner is intended only for household use. Read this Owner's Manual carefully for important use and safety information. This guide contains safety statements under warning and caution symbols. Please pay special attention to these boxes and follow any instructions given. **WARNING** statements alert you to such dangers as fire, electrical shock, burns and personal injury. **CAUTION** statements alert you to such dangers as personal injury and/or property damage.

UPRIGHT VACUUM CLEANER PARTS AND FEATURES

It is important to know your vacuum cleaner's parts and features to assure its proper and safe use. Review these before using your cleaner.

Item	Part No. In U.S.	Part No. In Canada
Exhaust Filter	20-86889	20-86889C
Headlight Bulb	20-5240	20-40600
Belt	20-5275	20-40096

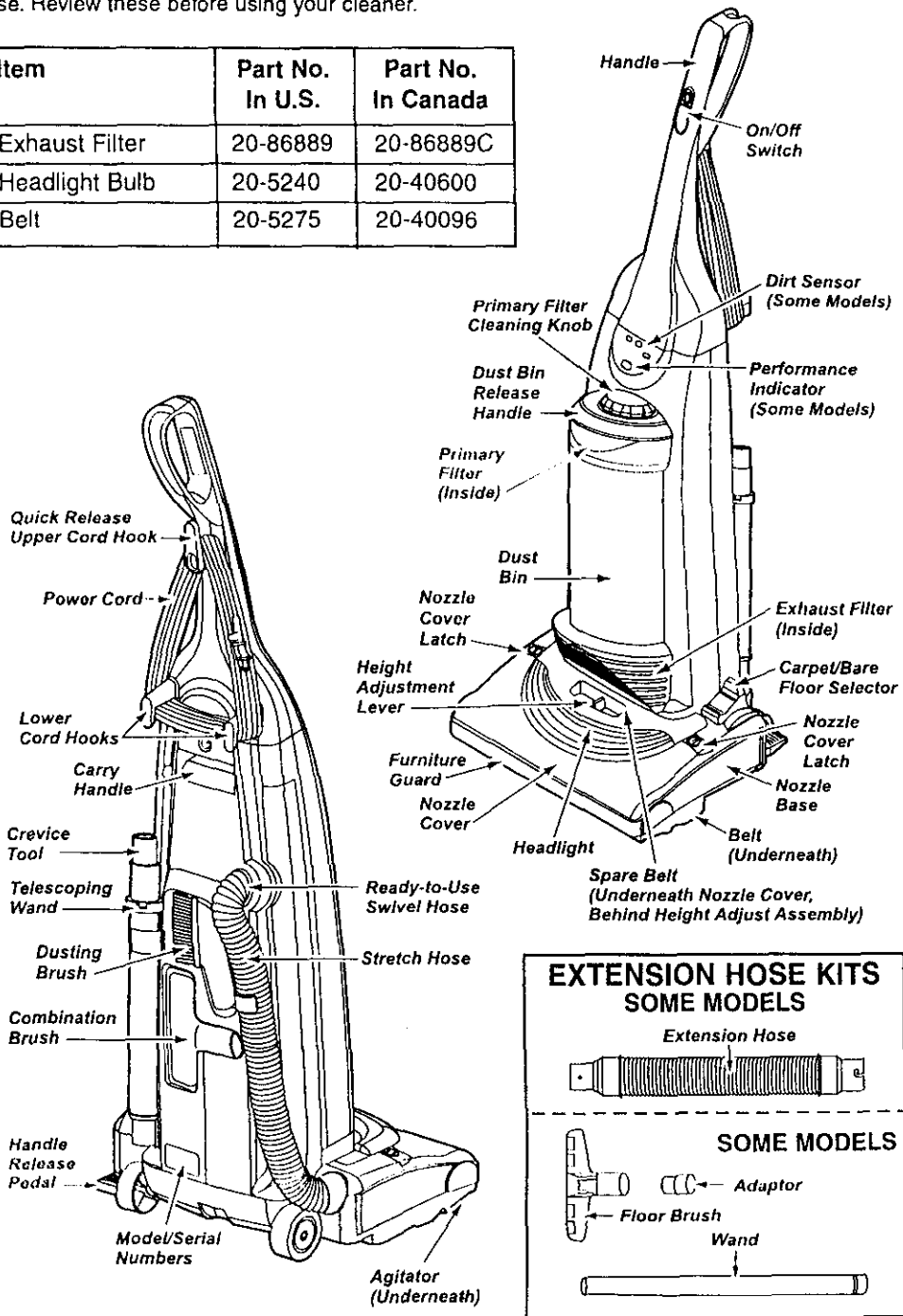



WARNING

Electrical Shock Hazard

Do not plug into the electrical supply until the assembly is complete. Failure to do so could result in electrical shock or injury.

HANDLE ASSEMBLY

Before assembling your vacuum cleaner, be sure you have all the parts as shown in PARTS AND FEATURES.

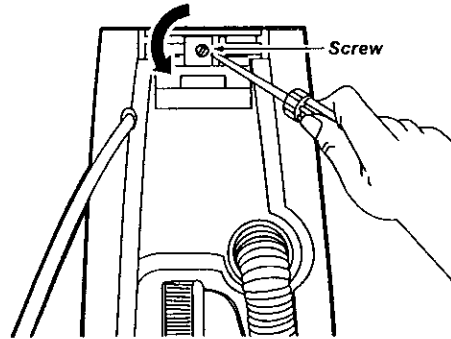

Remove the screw located just below the top edge of the back of the vacuum.

Position the handle as shown in the illustration below.

Slide the handle into the opening at the top of the vacuum.

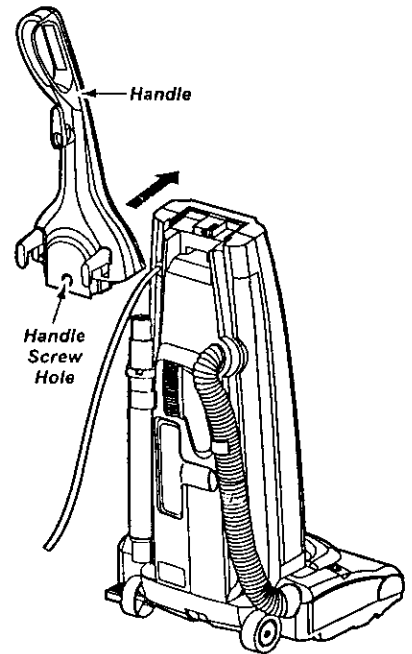

Insert the screw so it passes through the handle into the vacuum.

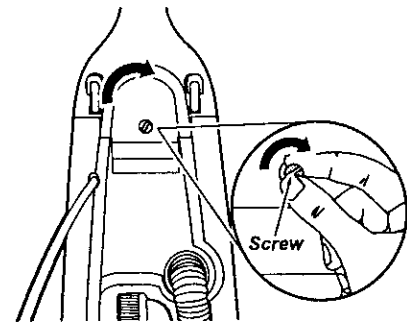

Begin to tighten the screw with your fingers. It may be necessary to adjust the handle slightly.

Using a screwdriver, tighten the screw.

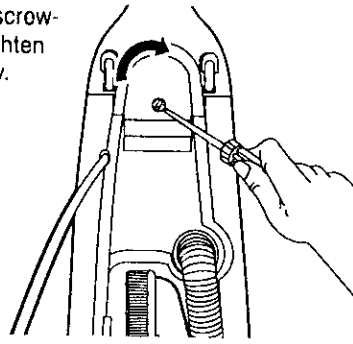

CAUTION

Do not overtighten. Overtightening could strip the screw holes.

Do not operate the cleaner without the screw in place.

CORD ASSEMBLY

Make sure the quick release upper cord hook is in the upright position. Remove the wire tie from the power cord.

Lock the cord into place by forcing it into the locking notch on the body of the quick release upper cord hook as shown. This helps keep the power cord out from under the vacuum cleaner agitator.

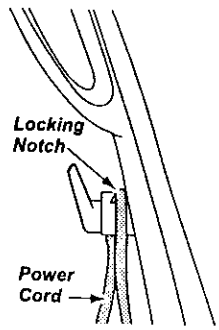

Wrap the power cord around the upper and lower cord hooks and lock the power cord plug onto the power cord.

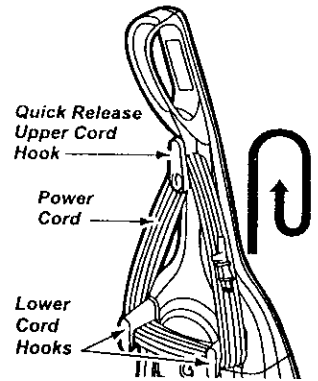

OPERATING INSTRUCTIONS

HOW TO START

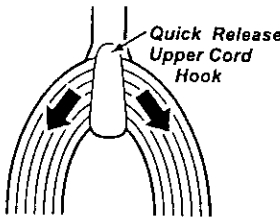

Turn the quick release upper cord hook to either side and down to release the power cord.

Release the power cord plug from the power cord and pull the cord off the quick release upper cord hook. Check to be sure the power cord is still locked into the lock in the quick release upper cord hook.

NOTE: To reduce the risk of electric shock, this vacuum cleaner has a polarized plug, one blade is wider than the other.

This plug will fit in a polarized outlet only one way. If the plug does not fit fully in the outlet, reverse the plug. If it still does not fit, contact a qualified technician to install the proper outlet. Do not change the plug in any way.

Plug the polarized power cord into a 120 Volt outlet located near the floor.

WARNING

Personal Injury and Product Damage Hazard

- DO NOT plug in if switch is in the ON position. Personal injury or damage could result.
- DO NOT use outlets above counters. Damage to items in surrounding area could occur.

PILE HEIGHT SELECTION AND SETTING

To select a pile height setting:

Turn off cleaner. Select a pile height setting by tilting the cleaner back until front wheels are lifted slightly off the floor as illustrated.

Slide the adjustment lever to the correct setting.

SUGGESTED PILE HEIGHT SETTINGS

You may need to raise the height to make some jobs easier, such as scatter rugs and longer pile carpets. Suggested settings are:

HIGH: shag carpet, long pile, plush, scatter rugs.

MED: medium to long pile.

LOW: short to medium pile.

EX LOW: very low pile.

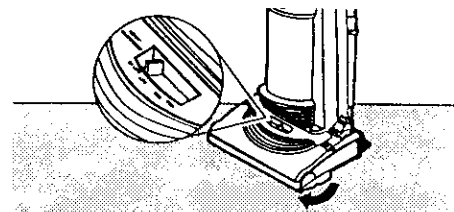

WARNING

Personal Injury Hazard

DO NOT place hands or feet underneath the unit when changing from the bare floor to the carpet pile height setting. The agitator begins to revolve rapidly when the vacuum is turned on and is in the carpet setting.

CARPET/BARE FLOOR SELECTOR

SOME MODELS

Bare floor setting: Slide the carpet/bare floor selector all the way back and down toward the bottom of the nozzle until it locks into place.

In this position the brush assembly does not revolve. This setting should be used for cleaning hardwood and tile floors and **when any attachments (tools) are used.**

Carpet setting: Slide the selector **all the way forward** and up to the carpet position.

In this position the brush assembly will turn. When carpets are being cleaned the selector should be in this position.

Attention: Refer to your carpet manufacturers cleaning recommendations. Some more delicate carpets may require that they be vacuumed with the agitator turned off, to prevent carpet damage.



CAUTION

Do not allow vacuum cleaner to remain in one spot for any length of time when the agitator is turning. Damage to carpet may occur.

Note: For longer belt life, turn vacuum off before moving selector, otherwise make sure the selector is pushed **fully and quickly as possible** to the desired position. Failure to do so can cause the belt to rub on the selector shaft and may result in the belt becoming hot and creating a burning rubber smell.

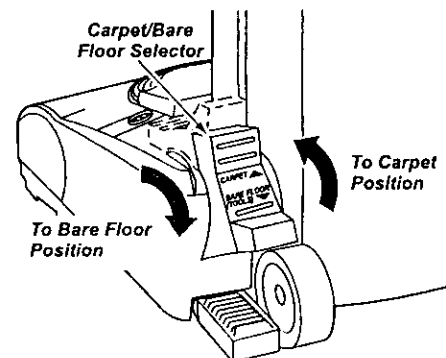

RELEASING THE HANDLE

Release the handle by pressing down on the handle release pedal with your foot and pulling back and down on the handle with your hand.

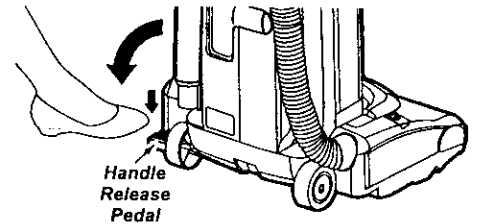

ON/OFF SWITCH

HANDLE MOUNTED SOME MODELS

To start the vacuum cleaner, slide the On/Off switch from the OFF position to the ON position. To stop the vacuum cleaner, slide the On/Off switch to the OFF position.

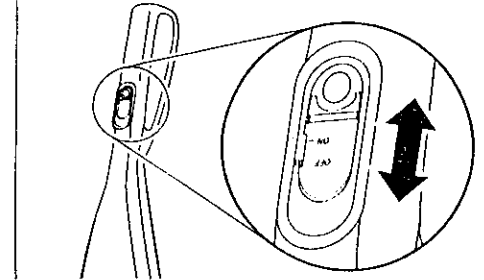

ATTACHMENTS

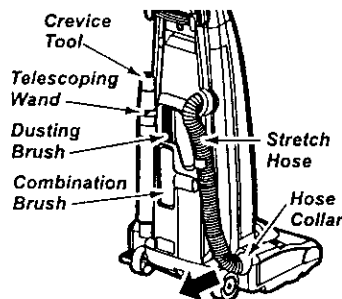

Identify each of the attachments shown above.

TO USE ATTACHMENTS:

Place the carpet/bare floor selector in the bare floor setting by rotating the selector back and down to the bare floor setting. See CARPET/BARE FLOOR SELECTOR section.

When returning the bare floor selector to the carpet setting, use caution as the selector can move quickly to that setting due to tension created by the belt.

Remove the lower end of the stretch hose from the cleaner by grasping the hose collar, twisting and pulling straight out. The attachments can now be added to the hose.

NOTE: The motor protector may open when using attachments or when cleaning new carpet, due to reduced airflow by the attachments themselves or by new carpet fuzz filling the dust bin quickly. See the TROUBLESHOOTING section.



WARNING

Electrical Shock And Personal Injury Hazard

Disconnect electrical supply before servicing or cleaning the unit. Failure to do so could result in electrical shock or personal injury from cleaner suddenly starting.

The attached hose swivels to make cleaning easier in every direction. Remove the hose from the hose clip by pulling straight out.

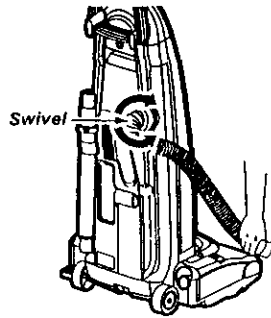

TELESCOPING WAND WITH SUCTION CONTROL SLIDE SOME MODELS

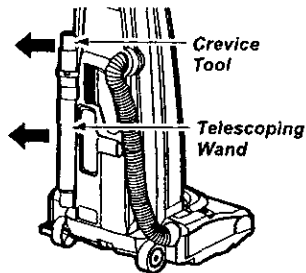

Remove the telescoping wand from its storage position.

Remove the crevice tool from its storage position in the wand. Turn the locking ring to the **UNLOCK** position.

Extend the wand to its full length. Turn the locking ring to the **LOCK** position. Attach the extension wand onto the open end of the hose.

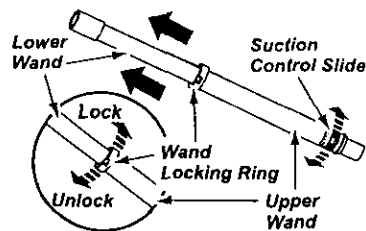

When using the dusting brush or the combination brush, they may be attached directly to the wand or placed on the end of the crevice tool.

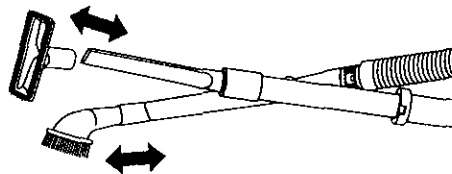

Align the tabs on the extension wand with the "J" slots in the hose. Push the wand into the hose and twist to the right to lock.

To achieve maximum reach with the attachments, add the crevice tool to the end of the wand by inserting and twisting slightly.

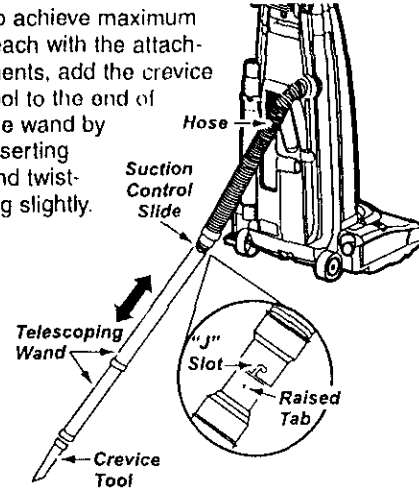

TO OPERATE SUCTION CONTROL SLIDE

Telescoping Wand

When using attachments for cleaning draperies, small rugs with low pile and other delicate items, twist the suction control slide to the open position. This lever is located on the telescoping wand, close to the hose.

This will reduce suction for ease of cleaning.

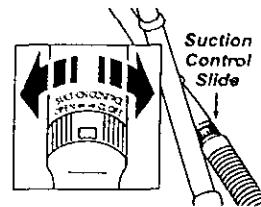

NOTE: Return suction control slide to the closed position for normal cleaning.

CAUTION

When using attachments, be careful not to overextend the stretch hose when reaching. Trying to reach beyond the hose stretch capability could cause the cleaner to tip over. Make sure the carpet/bare floor selector is in the bare floor position. Damage to the floor surface may occur if the carpet setting is used.

TO STORE ATTACHMENTS:

Remove dusting brush or combination brush. Snap into appropriate storage location.

Remove crevice tool from the wand by twisting. Lay aside.

Remove the extension wand from the hose. Twist the wand to the left and pull from the hose end.

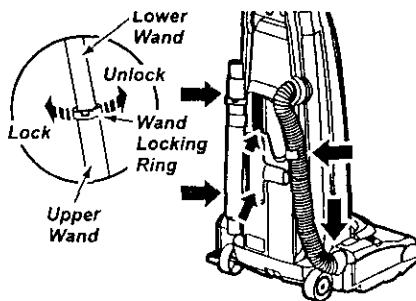

Unlock the wand by turning the wand locking ring to the **UNLOCK** position.

Slide the lower wand into the upper wand. Turn the wand locking ring to the **LOCK** position.

Place the crevice tool down into the compressed wand. Snap into the appropriate storage location.

Reinsert the hose fully into the opening on the lower body from which it was removed. Press firmly to assure connection.

CAUTION

DO NOT pull the vacuum cleaner around the room by the hose. Property damage could result.

EXTENSION HOSE: SOME MODELS

Some models include an extra hose which connects to the stretch hose on the vacuum for a longer cleaning reach.

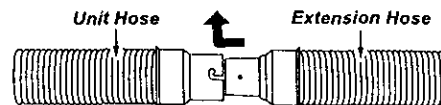

Insert the two tabs on the end of the extension hose into the two "J" shaped slots on the unit hose and twist to connect.

All attachments and the telescoping wand can be attached to the open end of the hose.

FLOOR BRUSH AND WAND: SOME MODELS

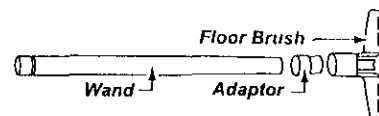

Some models have an extra brush and wand for cleaning bare floors. Twist one end of the adaptor into the floor brush and the other end into the straight wand. Connect the straight wand to the telescopic wand and then to the vacuum hose or extension hose.



CAUTION

When using the regular hose or with the extension hose attached, the cleaner should be on a solid surface on the same level or below the level of the user's feet. DO NOT use the hoses when the cleaner is above the level of the user's feet.

ATTACHMENT USE CHART

ATTACHMENT	CLEANING AREA				
	Furniture*	Between Cushions*	Drapes*	Stairs	Walls
DUSTING BRUSH 	X		X		X
CREVICE TOOL 	X	X		X	
COMBINATION BRUSH 	X		X	X	

*Always clean attachments before using on fabrics.

VACUUMING TIPS

Carpet edges.

Guide either side or the front of the nozzle along a baseboard. The full length brushes help remove dirt at carpet edges.

Stairs.

Put handle in full upright position. Place the carpet/bare floor selector in the bare floor position. Use the crevice tool or fabric brush. Set the On/Off switch to ON.

For best cleaning results, keep the air-flow passage clear.

Occasionally, check each of the areas indicated for clogs.

Unplug the cleaner from the outlet before checking.

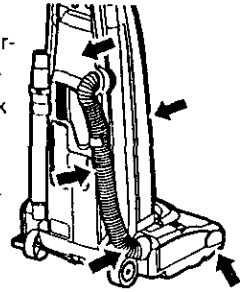

WARNING

Personal Injury Hazard

Use care if vacuum cleaner is placed on stairs. If it falls, personal injury or property damage could result.

PERFORMANCE FEATURES

MOTOR PROTECTION SYSTEM

Thermal Protector

This vacuum has a thermal protector which automatically trips to protect the vacuum from overheating. If a clog prevents the normal flow of air to the motor, the thermal protector turns the motor off automatically to allow the motor to cool in order to prevent possible damage to the vacuum. During this time the headlight remains on.

To correct problem: If this occurs, turn the vacuum off and unplug the power cord from the outlet to allow the vacuum to cool and the thermal protector to reset. **Check for and remove clogs, if necessary. Also check and clean/replace any clogged filters. Wait approximately thirty (30) minutes and plug the vacuum in and turn back on to see if the motor protector has reset. The motor protector will not reset if the vacuum is not turned off even if the vacuum has cooled down.**

PERFORMANCE INDICATOR SOME MODELS

When the unit is running with normal air flow, the light on the performance indicator is off. The light comes on whenever the airflow becomes blocked. If that occurs, check the dust bin, clean/replace clogged filters, and check other possible clog locations shown in CLOG REMOVAL.

To correct problem: See the TROUBLE-SHOOTING chart.

NOTE: The light may also come on when using attachments, due to reduced airflow through the attachment.

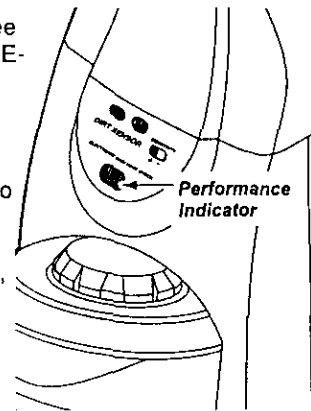

DIRT SENSOR SOME MODELS

The electronic dirt sensor is a feature which will detect particles as they pass through the vacuum cleaner.

The dirt sensor indicators and sensor sensitivity switch are located on the front of the switch cover.

A red light indicates dirt is being picked up by the cleaner. A green light indicates most of the dirt has been picked up by the cleaner.

OPERATION

As you vacuum, the red indicator light will come on and stay on as long as the sensor detects a high concentration of particles passing through the cleaner.

The green light indicates that most of the cleaning is complete.

The sensor switch allows you to select the sensitivity of the dirt sensor. The switch can be set to HI (+) or LO (-) sensitivity.

Set the sensor switch to the HI (+) position when:

- Cleaning bare floors.
- Cleaning carpet with low pile height.

Set the sensor switch to the LO (-) position when:

- Cleaning heavily soiled areas.
- Cleaning carpet with deep pile.
- Cleaning new carpets.

Even with the sensor switch in the LO (-) position, the dirt sensor will detect carpet fuzz, especially on new carpet, which may cause the red light to remain on longer than expected.

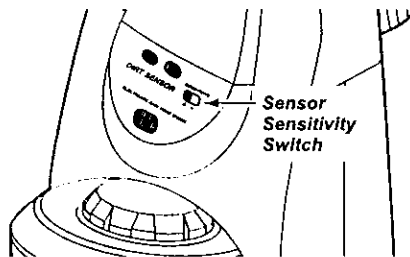

! WARNING

Electrical Shock And Personal Injury Hazard

Disconnect electrical supply before servicing or cleaning the unit.

Failure to do so could result in electrical shock or personal injury from cleaner suddenly starting.

TO CLEAN DIRT SENSOR OPTICS

The dirt sensor optics consist of two optic cells located inside the dust bin port. Occasionally, it may become necessary to clean the two optic cells to assure maximum performance. It is recommended the optic cells be cleaned:

- When the red light stays on continuously.
- When the green light stays on continuously.
- When dirt or dust adheres to the optic cells.
- Whenever the dust bin is cleaned.

To clean the sensor, wipe the optic cells with a soft, dry cloth. Never use cleaners or liquids as they can help speed the recoating of the optic cells and make it necessary to clean them much sooner than normal. The dirt sensor area can be reached by removing the dust bin.

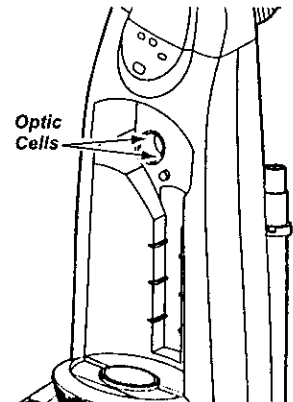

VACUUM CLEANER CARE

Always follow all safety precautions when cleaning and servicing the vacuum cleaner.



WARNING

Electrical Shock And Personal Injury Hazard

Disconnect electrical supply before servicing or cleaning the unit. Failure to do so could result in electrical shock or personal injury from cleaner suddenly starting.

VACUUM STORAGE

Gather the cord and wrap it loosely around the upper and lower cord hooks.

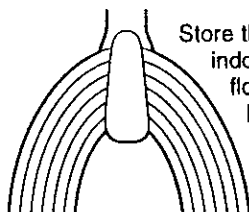

Store the cleaner in a dry, indoor area, on the floor with the handle locked in the upright position.



WARNING

Electrical Shock And Personal Injury Hazard

Wrapping the cord too tightly puts stress on the cord and can cause cord damage. A damaged cord is an electrical shock hazard and could cause personal injury or damage.

CLEANING EXTERIOR AND ATTACHMENTS

Unplug cord from wall outlet. **DO NOT** drip water on cleaner.

Clean exterior using a clean, soft cloth that has been dipped in a solution of mild liquid detergent and water, then wrung dry. Wipe dry after cleaning.

To reduce static electricity and dust build-up, wipe outer surface of cleaner and attachments.

Wash attachments in warm soapy water, rinse and air dry. **Do not clean in dishwasher.**

DO NOT USE ATTACHMENTS IF THEY ARE WET.



CAUTION

Attachments used in dirty areas, such as under a refrigerator, should not be used on other surfaces until they are washed. They could leave marks.

DUST BIN CLEANING

Always empty the dust bin when dirt level reaches the "MAX" line.

TO REMOVE DUST BIN:

 **WARNING**
Always unplug power cord from electrical outlet before performing any service on vacuum.

Lift dust bin handle located at the top of the dust bin.

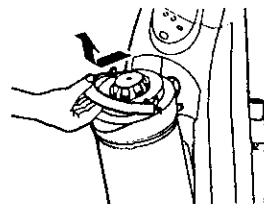
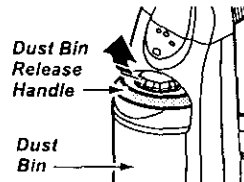

Pull the handle forward and lift dust bin up and out of the vacuum cleaner.

Every time dust bin is removed, rotate cleaning knob on top of dust bin at least two complete revolutions to activate filter cleaning system and to maintain cleaning performance.

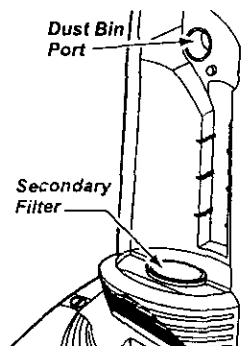
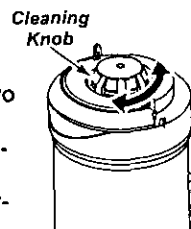

Remove any clogs that might be located in the dust bin port or the secondary filter.

TO EMPTY DUST BIN:

Rotate dust bin lid counterclockwise and lift off.

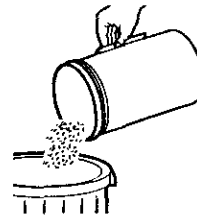
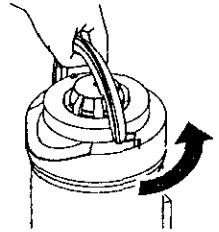

Pour dust bin contents into a trash container.

TO REPLACE DUST BIN:

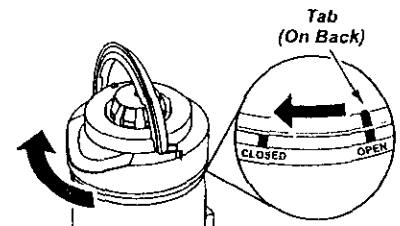

Replace dust bin lid by placing back on dust bin with the tab on the lid aligned with the word "OPEN" on the back of the dust bin. Rotate lid clockwise while pressing downward so that the handle aligns with the front of the dust bin.

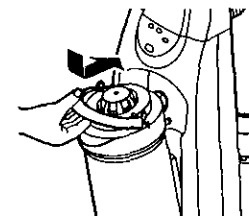

Place dust bin back into vacuum cleaner by inserting the bottom first and tilt back with the dust bin handle raised.

Lower the dust bin handle to lock dust bin in place.



FILTER CHANGING/CLEANING



WARNING

Electrical Shock Hazard

Unplug power cord from electrical outlet. Do not operate the cleaner without the primary filter. Be sure the filter is properly installed to prevent motor failure and/or electrical shock.

PRIMARY FILTER

The filter **CANNOT** be washed as it will lose its dust trapping ability.

Check primary filter frequently and clean when dirty.

TO REMOVE PRIMARY FILTER:

Remove the dust bin and dust bin lid as outlined in the DUST BIN CLEANING section.

Remove filter cover by pushing in at tabs located beneath handle hinges, and lifting off.

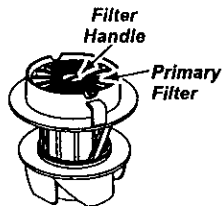
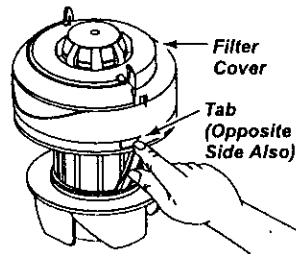

Grasp filter handle and lift out.

Clean primary filter by gently tapping over a trash container.

TO REPLACE PRIMARY FILTER:

Replace filter and rotate it until handle drops into the slots.

Check sliders and remove any obstructions

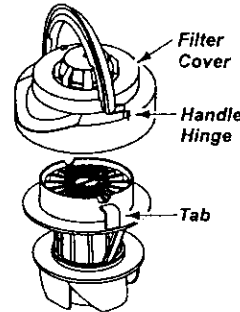
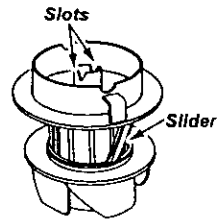

Replace dust bin lid by snapping into place with handle hinges aligned to tabs.

Replace the dust bin as outlined in the DUST BIN CLEANING section.

EXHAUST FILTER

HEPA

The exhaust filter cartridge must be replaced when dirty. It should be replaced regularly depending on use conditions. The filter **CANNOT** be washed as it will lose its dust trapping ability.



WARNING

Do not operate without exhaust filter.

NOTE: See PARTS AND FEATURES for the exhaust filter #.

Press inward on each side of exhaust filter cover and pull out to remove from vacuum cleaner.

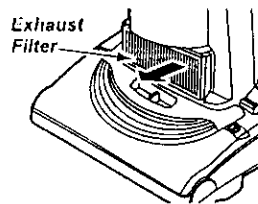
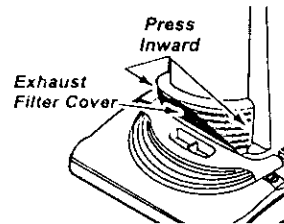

Remove the exhaust filter cartridge.

Replace the exhaust filter cartridge, carefully positioning it so that it fits into the motor cover. **The grey edge of the filter should be facing away from the operator.** Push only on filter cartridge frame, not on filter itself.

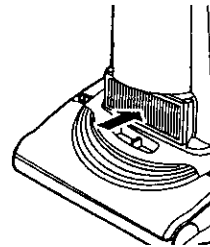

Replace the exhaust filter cover by placing tabs in slots and pushing in until cover snaps into place.

SECONDARY FILTER

FOAM

Check secondary filter frequently and change when dirty.



WARNING

Electrical Shock Hazard

Do not operate the cleaner without the motor safety filter. Be sure the filter is dry and properly installed to prevent motor failure and/or electrical shock.

Remove the dust bin as outlined in the DUST BIN CLEANING section.

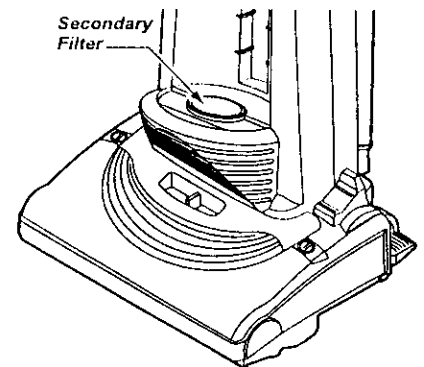

Remove secondary filter from vacuum cleaner.

Wash the secondary filter in warm soapy water, rinse and dry thoroughly by squeezing the filter in your hand and letting it air dry.

DO NOT wash in the dishwasher.

DO NOT install damp.

Replace dry secondary filter. Ensure filter is properly installed over filter opening.

Replace the dust bin as outlined in the DUST BIN CLEANING section.

BELT CHANGING AND AGITATOR CLEANING



WARNING

Electrical Shock Or Personal Injury Hazard
 Disconnect electrical supply before servicing or cleaning the unit.
 Failure to do so could result in electrical shock or personal injury from cleaner suddenly starting.

Frequently check and remove hair, string and lint build-up in the brush area. If build-up becomes excessive, follow the steps below.

TO REMOVE BELT:

Disconnect power cord from electrical outlet.

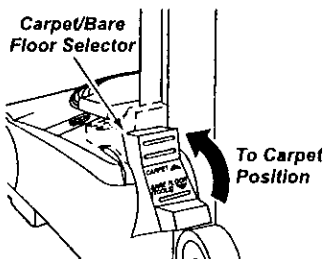

Place the carpet/bare floor selector in the carpet position and lower handle to lay vacuum flat.

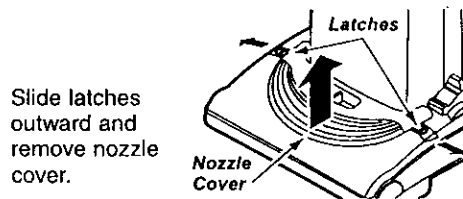

Slide latches outward and remove nozzle cover.

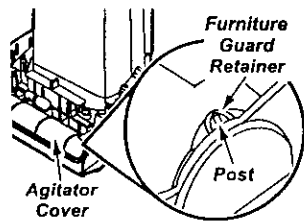

Unfasten the furniture guard retainers from the posts on both sides of the agitator cover.

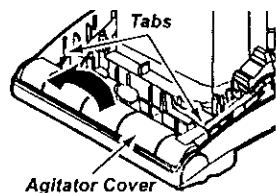

Depress tabs on rear of agitator cover and rotate forward to release from the nozzle body.

The light bulb socket assembly does not have to be removed. Lay the agitator cover over to the side out of the way.

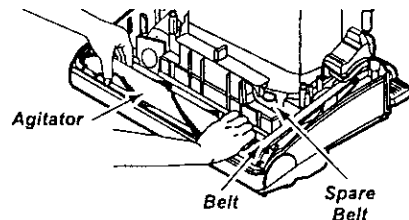

Position hands on the agitator. If the belt is still attached to the agitator, there will be tension on the agitator. Carefully lift the right end of the agitator and then the left end.

NOTE: It may be necessary to pull the edge of the furniture guard out of the way to allow the ends of the agitator to be removed easily.

Remove the belt from the motor drive shaft.

A spare belt is provided. See above illustration for location of spare belt. You may keep a spare belt in this location any time.



WARNING

Personal Injury Hazard
 Be careful when removing the agitator as the belt tension is high.
 Failure to do so could result in personal injury from the agitator releasing quickly and snapping away.

TO CLEAN AGITATOR:

NOTE: In order to keep cleaning efficiency high and to prevent damage to your vacuum, the agitator must be cleaned every time the belt is changed.

The agitator must also be cleaned every 7 to 10 uses.

Remove any dirt or debris in the belt path area or in the agitator area.

Exploded View - Agitator Assembly

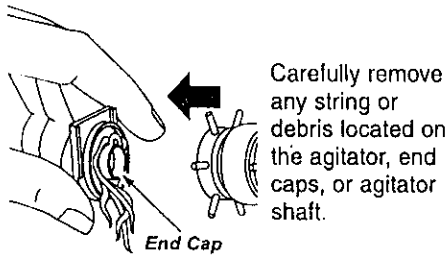
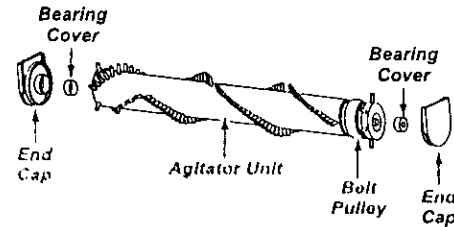

Replace the end caps. See the exploded view for correct assembly.

TO REPLACE BELT:

Make sure that the carpet/bare floor selector is in the **carpet** position. Loop the new belt on the **motor shaft**.

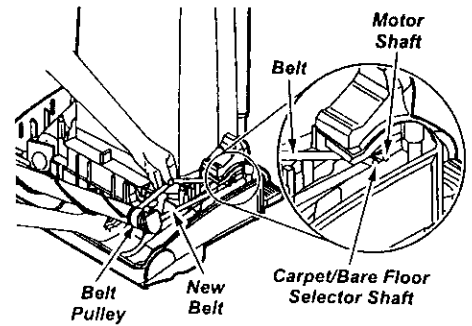

BELT ROUTING

Correct Routing of Belt (Selector in Carpet Position)

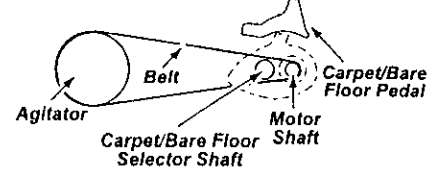

Incorrect Routing of Belt (Belt on Selector Shaft)

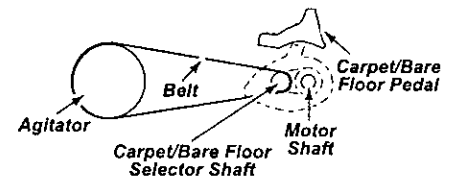

Incorrect Routing of Belt (Selector in Bare Floor Position)

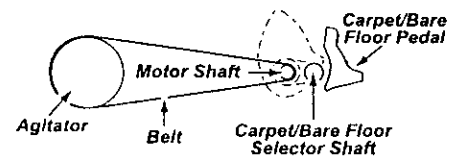

NOTE: See PARTS AND FEATURES for belt #.

Loop the other end of the belt on the belt pulley on the agitator.

Insert the agitator by placing the rounded portion of the end cap down into the slot in the nozzle base.

NOTE: It may be necessary to hold the furniture guard out of the way in order to allow proper insertion of the agitator into the nozzle base.

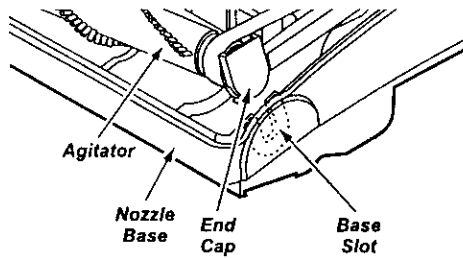

NOTE: Care must be taken due to the belt tension during reassembly.

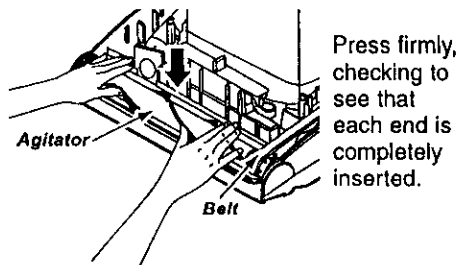

Check to see that the belt is centered on the belt pulley. Turn the agitator with your fingers to see that it turns freely.

To re-attach the agitator cover, insert the six (6) tabs into the six slots along the front edge of the nozzle base.

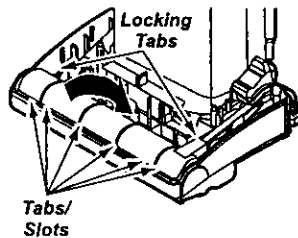

Lower the agitator cover to its original position. After positioning the agitator cover, push forward on the two (2) locking tabs in order to ensure that they are securely in place.

Re-fasten the furniture guard retainers to the posts on both sides of the agitator cover.

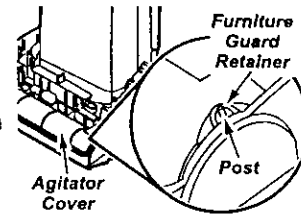

NOTE: If the agitator cover is not installed correctly, you may experience a loss of performance and possible agitator vibration, etc.

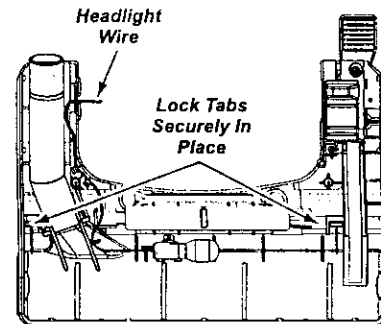

Make sure the headlight wires are tucked securely in place.

Replace the nozzle cover and secure the latches.

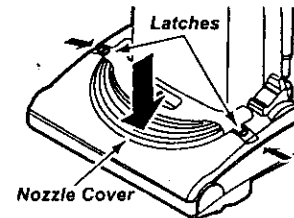

CLOG REMOVAL

Always follow all safety precautions when cleaning and servicing the vacuum cleaner.



WARNING

Electrical Shock Or Personal Injury Hazard
Disconnect electrical supply before servicing or cleaning the unit. Failure to do so could result in electrical shock or personal injury from cleaner suddenly starting.

If the cleaner does not seem to have adequate suction, first check if the dust bin is full or if a filter is clogged. See DUST BIN CLEANING and FILTER CHANGING.

If the dust bin and filter areas are free of clogs, check the hose area. Remove the lower end of the stretch hose from the cleaner by grasping the hose collar, twisting, and pulling straight out.

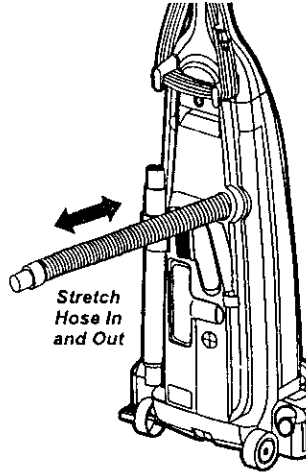

Plug in the vacuum and turn it on. Stretch the hose to maximum length and then allow the hose to return to its storage length. Turn the unit off and unplug the unit.

Visually inspect the hose and the base area into which the hose is inserted.

Remove any visible clog.

Re-insert the hose into the opening on the lower body from which it was removed. Press firmly to assure connection.

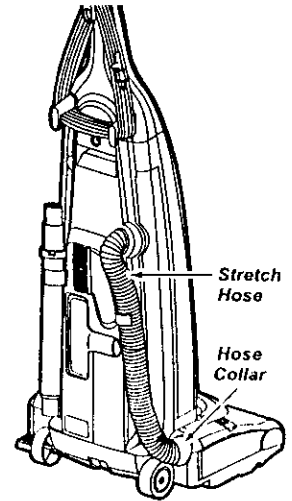

WARNING

Personal Injury Hazard
DO NOT place hands or feet underneath the unit at any time. The agitator will be revolving rapidly when the vacuum is turned on and is in the carpet setting.

If the dust bin and filter areas and the hose areas are free of clogs, check the nozzle area. To check this area, see the section on BELT CHANGING AND AGITATOR CLEANING.

Return the cleaner to the upright position before plugging into an electrical outlet.

LIGHT BULB CHANGING



WARNING

Electrical Shock Or Personal Injury Hazard

Disconnect electrical supply before servicing or cleaning the unit. Failure to do so could result in electrical shock or personal injury from cleaner suddenly starting.

TO REMOVE LIGHT BULB:

Disconnect power cord from electrical outlet. Place the carpet/bare floor selector in the carpet position and lower handle to lay vacuum flat.

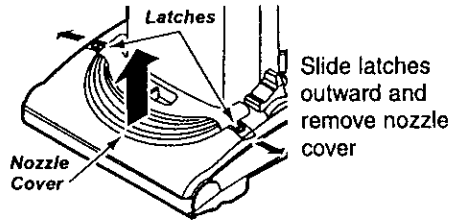

Slide latches outward and remove nozzle cover



CAUTION

Do not use a bulb rated over 15W. During extended use, heat from the bulb could overheat surrounding plastic parts.

Remove the light bulb by pushing the bulb in while turning counterclockwise to release from the slot. Then pull the light bulb straight out.

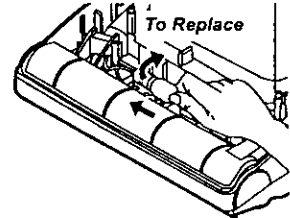
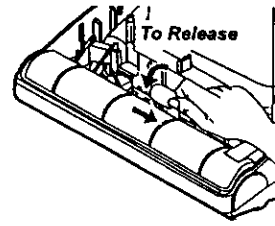

To replace the light bulb carefully insert and turn clockwise to securely fit into slot.

NOTE: See PARTS AND FEATURES for bulb #.



CAUTION

Do not plug in or turn on until the vacuum is completely reassembled.

Replace the nozzle cover and secure the latches.

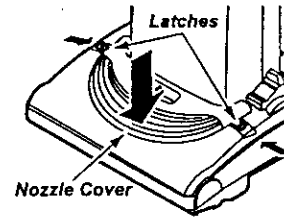

AGITATOR SERVICING



WARNING

Electrical Shock Or Personal Injury Hazard

Disconnect electrical supply before servicing or cleaning the unit. Failure to do so could result in electrical shock or personal injury from cleaner suddenly starting.

TO CHECK AGITATOR:

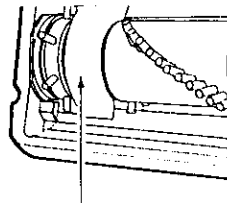

Base Plate Belt Guard

Turn the vacuum over to check for worn brushes. When brushes are worn to the level of the base belt guard, replace the agitator.

TO REPLACE AGITATOR:

Remove the nozzle cover, agitator cover and agitator. See BELT CHANGING AND AGITATOR CLEANING.

Remove the end caps and bearing covers.

Replace the agitator with a new one.

Replace the bearing covers and end caps.

Reassemble the belt, agitator, agitator cover and nozzle cover. See "To replace belt" in BELT CHANGING AND AGITATOR CLEANING section.

AGITATOR ASSEMBLY

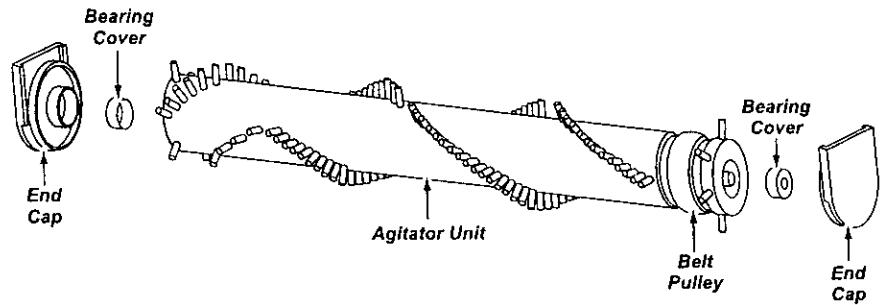

TROUBLESHOOTING

Review this chart to find do-it-yourself solutions for minor performance problems. Any service needed, other than those described in this owner's manual, should be performed by an authorized service representative.



WARNING Electrical Shock Hazard

Disconnect electrical supply before servicing or cleaning the unit. Failure to do so could result in electrical shock or personal injury.

PROBLEM	POSSIBLE CAUSE	POSSIBLE SOLUTION
Cleaner won't run.	<ol style="list-style-type: none"> 1. Unplugged at wall outlet. 2. Tripped circuit breaker/blown fuse at household service panel. 3. On/off switch not turned on. 4. Thermal protector tripped. 	<ol style="list-style-type: none"> 1. Plug in firmly, push on/off switch to on. 2. Reset circuit breaker or replace fuse. 3. Push on/off switch to on. 4. Reset thermal protector, (page 11)
Poor job of dirt pick-up.	<ol style="list-style-type: none"> 1. Full or clogged dust bin. 2. Wrong pile height setting. 3. Worn agitator. 4. Clogged nozzle or dust bin port. 5. Clogged hose. 6. Hole in hose. 7. Broken/misplaced belt. 8. Hose not inserted fully. 9. Motor protection system activated. 10. Dirty filters. 11. Sliders not rotating. 	<ol style="list-style-type: none"> 1. Clean dust bin, (page 14). 2. Adjust setting, (page 7). 3. Replace agitator, (page 22). 4. Check CLOG REMOVAL, (page 20). 5. Check for clogs, (page 20). 6. Replace hose. 7. Replace/fix belt, (page 17-19). 8. Insert hose fully, (page 10). 9. Check for clogs, (page 20). 10. Clean/change filters, (page 15-16). 11. Remove obstructions, (page 15).
Cleaner picks up moveable rugs or pushes too hard.	<ol style="list-style-type: none"> 1. Wrong pile height setting. 	<ol style="list-style-type: none"> 1. Adjust setting, (page 7).
Light won't work.	<ol style="list-style-type: none"> 1. Burned out light bulb. 	<ol style="list-style-type: none"> 1. Change light bulb, (page 21).
Agitator does not turn.	<ol style="list-style-type: none"> 1. Broken belt. 2. Bare floor selector in bare floor setting. 3. Belt installed incorrectly. 	<ol style="list-style-type: none"> 1. Replace belt, (pages 17-19). 2. Move selector to the carpet setting, (page 7). 3. Check BELT CHANGING AND AGITATOR CLEANING, (pages 17-19).
Performance indicator, some models, is red.	<ol style="list-style-type: none"> 1. Full or clogged dust bin. 2. Dirty filters. 3. Clogged airflow passage. 4. Certain attachment tools. 	<ol style="list-style-type: none"> 1. Clean dust bin, (page 14). 2. Clean/change filters, (page 15-16). 3. Clear clog from airflow passage, (page 20). 4. This is normal. Light should go off when tool is removed.
Air flow restricted with attachment use. Sound changes.	<ol style="list-style-type: none"> 1. Attachment use restricts air flow. 2. New carpet fuzz clogged air path. 	<ol style="list-style-type: none"> 1. Check ATTACHMENTS, (page 8) 2. Check CLOG REMOVAL and clean hose, (page 20).
Excessive noise as vacuum is shut off.	<ol style="list-style-type: none"> 1. Belt rubbing on carpet/bare floor selector shaft. 	<ol style="list-style-type: none"> 1. Push selector all the way forward, (page 7).
Dirt Sensor, some models, will not work.	<ol style="list-style-type: none"> 1. Dirty optic cells. 	<ol style="list-style-type: none"> 1. Clean optic cells, (page 12).

Get it fixed, at your home or ours!

For repair of major brand appliances in your own home...
no matter who made it, no matter who sold it!

1-800-4-MY-HOMESM Anytime, day or night
(1-800-469-4663)

www.sears.com

To bring in products such as vacuums, lawn equipment and electronics
for repair, call for the location of your nearest **Sears Parts & Repair Center.**

1-800-488-1222 Anytime, day or night

www.sears.com

For the replacement parts, accessories and owner's manuals
that you need to do-it-yourself, call **Sears PartsDirectSM**

1-800-366-PART 6 a.m. – 11 p.m. CST,
(1-800-366-7278) 7 days a week

www.sears.com/partsdirect

To purchase or inquire about a Sears Service Agreement:

1-800-827-6655

7 a.m. – 5 p.m. CST, Mon. – Sat.

Para pedir servicio de reparación a domicilio,
y para ordenar piezas con entrega a domicilio:

1-888-SU-HOGARSM
(1-888-784-6427)

Au Canada pour service en français:

1-877-LE-FOYERSM
(1-877-533-6937)



© Sears, Roebuck and Co.

® Registered Trademark / ™ Trademark of Sears, Roebuck and Co.
® Marca Registrada / ™ Marca de Fábrica de Sears, Roebuck and Co.