



# **Operator's Manual**

**PGD2000 & PGD3200**



## Table of Contents

Introduction.....	3
Safety Warnings .....	4
Operating Instructions.....	6
Service and Maintenance.....	10
Servicing of Hammer and Anvil.....	13
Reassembly.....	15
Troubleshooting.....	17
Warranty/Contact Info.....	19
Parts Diagram/List.....	21

# Introduction

Thank you for choosing Titan Gas-Powered Post Drivers. The performance of this tool is dependent upon your knowledge of the information contained in this operator's manual and your understanding of the operation and care of the engine installed on your Titan Post Driver.

This post driver is powered by a Honda GX35 engine. Honda supplies its own operator's manual, which covers all aspects of operating and maintaining your Honda engine. The Honda manual is provided to you along with this Titan Post Drivers operator's manual. Keep both manuals with your machine for reference by all operators. Follow all recommended maintenance for both the Titan Post Driver and the Honda engine.

Your Titan Post Driver comes with a one-year parts warranty (see the *Warranty* section of this manual). We suggest that you read the warranty information and fully understand its coverage and your responsibilities of ownership. To register your Titan Post Driver, go to <https://www.titanpostdrivers.com/warranty-registration/> and fill out the warranty registration form.

The Honda warranty is separate from the Titan Post Drivers warranty and is subject to its own coverage conditions and responsibilities of ownership. You can find the Honda warranty included with your Honda operator's manual.

Please contact Titan Post Drivers at (702) 293-4262 for parts or technical questions related to your post driver warranty. Please contact your local Honda service dealer for parts or technical questions related to your engine.



***Titan PGD2000 with 2" Barrel***



***Titan PGD3200 with 3 1/4" Barrel***

# Safety Warnings

This post driver is intended for use by informed adults only. Never allow children or uninformed persons to operate this machine. Never let your post driver run unattended. When not in use, turn the driver off to prevent unauthorized persons from using it.

**DO NOT** use the Titan Post Driver for any purpose other than driving posts or rods into the ground. Misuse may result in serious injury to yourself or others, as well as damage to your driver or other surrounding property.

## Personal Protective Equipment (PPE)

Always use approved protective equipment. Operators and all other persons in the immediate working area must wear protective equipment as well. Noise emitted from the machine while working can reach above 100 decibels, which can also harm others in close proximity. Please consider this while operating. We recommend the following personal protective equipment:

- Class 4 (SLC80 = 22.4 dB) hearing protection or greater
- Impact-resistant (ANSI Z87+) eye protection with side guards
- Protective gloves
- Protective boots

## Underground Utilities

Prior to driving any object into the ground, always have the location of underground utilities identified by a certified locating service. You can call 811, the national Call-Before-You-Dig call line, to request this service. Driving posts or rods into an underground utility line can be extremely dangerous. Severe or life-threatening personal and property damage can occur. Be absolutely certain you know where the underground utilities are located. Underground utilities that may be present include, but are not limited to, electric, gas, telephone, water, sewer, TV cable, or lawn sprinkler lines.

## Gasoline and Exhaust

Gasoline is highly flammable and explosive. You can be seriously injured when not handling and storing gasoline properly. Always use an approved gas storage container for your fuel. Never attempt to add gasoline to your Titan Post Driver while the engine is hot or running, as there is a chance of fumes igniting and causing severe personal damage, as well as damage to your machine.

Never use the Titan Post Driver inside a building or unventilated area. The engine exhaust contains poisonous carbon monoxide gas that can build up to dangerous levels in closed areas. These fumes can cause unconsciousness or death.

## Vibration Hazard Warning

Prolonged use of a power tool exposes the operator to vibrations, which may cause white finger disease or carpal tunnel syndrome. These conditions reduce the ability of the hands to feel and regulate normal temperature, produce numbness and burning sensations, and may even cause nerve and circulation damage. If numbness, tingling, pain, clumsiness, weakened grip, whitening of the skin, or any other symptoms occur at any time when operating the machine, or after operating the machine, immediately discontinue use of the machine and seek medical attention. Continued use of the machine after the occurrence of any such symptom may increase the risk of symptoms becoming more severe and/or permanent.

- Titan Post Drivers are designed with internal spring-dampened handles to reduce the amount of vibration transmitted to the operator.
- Wear gloves for comfort and grip. Keep hands warm while operating.
- Check the machine for loose connectors and components, as these could lead to increased levels of vibration.
- Always keep a firm grip on the handles, but **DO NOT** excessively squeeze the handles.

## Maintenance Warning

If the warning label on your post driver is not able to be read clearly, replace it immediately. Call Titan Post Drivers for a new warning label at no cost to you.

Regular maintenance is a prerequisite for keeping the machine safe and effective. Carefully follow all the operating instructions in this manual. Any damage or malfunction caused by unauthorized use, parts, or modifications to the machine will not be covered by warranty or carry any significance for any type of product liability.

- Change damaged parts immediately.
- Replace worn components as soon as they are identified.
- When cleaning mechanical parts with solvent, make sure to comply with safety precautions on the cleaning product labels, and make sure you have adequate ventilation.
- Engine maintenance is to be carried out according to the Honda specifications found in the Honda GX35 manual. The operator needs to take careful note of all warnings and dangers outlined in the engine manual.
- For major service or repairs to the machine, contact Titan Post Drivers directly at (702) 293-4262.
- For engine service or repairs, contact your local Honda dealer.

# Operating Instructions

Your Titan Post Driver is designed to be as effective and efficient as possible, while being extremely powerful and lightweight. It is very important to understand that your post driver is a powerful machine. With proper use and maintenance, your Titan Post Driver will provide you with many years of service.

**To reduce the risk of serious injury or death, you must read and understand the safety and operating instructions in this operator's manual. Each and every new person who uses this machine must be educated and fully understand this operator's manual. Never allow an uninformed person to use your Titan Post Driver.**

- The Titan Gas-Powered Post Driver is 100% self-contained. No other sources of power such as hydraulics or air compressors are required.
- Various sizes of reducer sleeves are available for the PGD2000 and PGD3200 to use on ground rods, rebar, and other types of stakes. Always use the reducer sleeve that most closely matches (best fits) the size of your post, as this ensures proper impact and minimizes wear.
- Always keep the driver square to the post when driving.
- Be sure to read and understand the starting instructions for the Honda GX35 engine.
- Your Honda GX35 engine is inclinable, which means it is designed to operate at any angle.
- For optimum performance, the machine is designed to be used with low-grade viscosity grease. We recommend Titan EP 0. Any other type of grease will be detrimental to the function of the machine.

**For optimum performance and to prevent the potential for dry-fire or misfire, please follow these guidelines:**

1. **ALWAYS** maintain 10-12 pounds of down-pressure while driving a post.
2. **ALWAYS** keep the driver square to the post while driving.
3. **ALWAYS** use the correct size sleeve for the type of post you are driving.
4. **DO NOT** allow the barrel of the driver to come in contact with the ground while driving.
5. **DO NOT** push the throttle trigger unless the driver is loaded on the post.
6. Your driver will arrive with grease in the crank. **DO NOT ADD ANY ADDITIONAL GREASE UNTIL NECESSARY.** Check the crank grease level regularly using the procedure described in the *Service and Maintenance* section of this manual. You will
7. In the event of dry-fire or misfire, you will need to re-engage the anvil by lifting the driver up and setting it back down on the post with some pressure applied.
8. Continual dry-fire or misfire will cause damage to your driver, which will not be covered under the terms of the warranty.

## Always follow these guidelines before you start your machine!

- Check Oil: **ADD ENGINE OIL WHEN NEW. OIL IS DRAINED FROM ENGINE AFTER TESTING FROM FACTORY.** Honda suggests adding less than 80 cm<sup>3</sup> (2.7 US oz., 2.8 Imp. oz.), then checking. Add oil if required to fill to the bottom edge of the oil fill hole. Use 10W-30 oil. **DO NOT OVERFILL.** Always hold driver in upright position to check oil level. Proper oil level is essential for the correct operation of the post driver. Overfilling the oil will result in loss of power and could cause permanent damage to your engine.
- Check Fuel Level: **ONLY USE UNLEADED FUEL WITH 86 OCTANE OR HIGHER.**
- Visually check the anvil and the barrel. Look up into the barrel for excessive debris or foreign objects.
- Check all fasteners and tighten as necessary. Follow torque requirements specified in the *Reassembly* section of this manual.
- **DO NOT** use your Titan Post Driver if there is any damage or wear to any of the controls or safety devices.
- Be sure to use all personal protective equipment as outlined in the *Safety Warnings* section of this manual.

## Safe Starting

- Place the machine on a secure, solid surface in an open area. Maintain a safe posture and balance. **DO NOT** start the driver anywhere except in an open, well-ventilated area. Never use your machine inside an enclosed building.
- When you pull the starter grip, **DO NOT** wrap the starter rope around your hand or wrist. **DO NOT** allow the grip to snap back, but rather guide the starter rope slowly back to permit the rope to rewind properly. **DO NOT** extend the starter rope to its full length. Failure to follow this procedure may result in serious injury to hand or fingers or may damage the starting mechanism.
  1. If the engine is cold, close the choke by moving the choke lever up.
  2. Press the priming bulb until fuel can be seen inside the fuel return line.
  3. Pull on the starter grip to start the engine, and gently return the starter grip to the normal position.

## Restarting a Hot Engine

- If the engine is operated at a high ambient temperature for a lengthy amount of time and then turned off to sit for a short time to cool off, it may not restart on the first pull. **IF NECESSARY**, use the following procedure. Failure to do so may result in personal injury.
  1. Move the choke lever down to the "OPEN" position.
  2. Hold the throttle in the max speed position while holding in the on-off auto reset button.
  3. Pull the starter grip 3 to 5 times.
  4. Follow the safe starting procedures listed above and start the engine with the choke in the "OPEN" position.

## Driving a Post

- Be sure to use all personal protective equipment as outlined in the *Safety Warnings* section of this manual.
- Start the engine safely as outlined on the previous page.
- Take a firm stance with weight evenly distributed on both feet. Keep both feet securely planted at a minimum of shoulder width apart. **ALWAYS** maintain a solid balance while driving posts.
- Lift the post driver onto the post, then ensure that the driver is level with the post and the post is centered up in the barrel of the post driver. To keep the driver square to the post, use the correct adapter sleeve. **If not aligned properly, you could cause damage to the machine or your post.** See Figure 1.

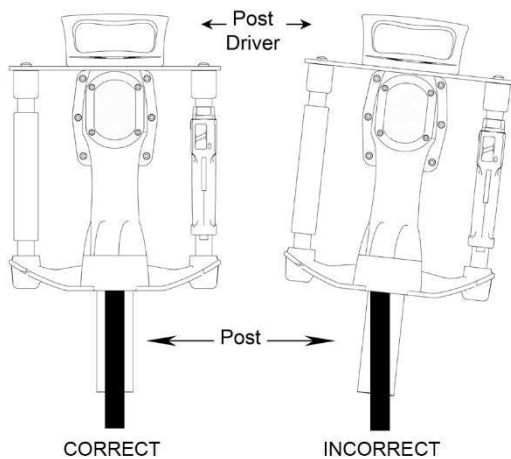

**Figure 1: Post driver level/square example**

- Pull down on the machine handles to apply approximately 10-12 pounds of down-pressure to help the internal hammer mechanism remain in the correct operating position. Once you are confident that the machine is being held level and the post is centered, gently engage the throttle trigger until the hammer action is felt.
- When you are sure the post is moving down into the ground correctly, depress the throttle trigger fully, and drive your post down to the desired depth. **ALWAYS** keep both hands on the driver and maintain the 10-12 pounds of down-pressure while driving the post into the ground.
- Be sure the barrel of the driver does not come in contact with the ground. This will take the down-pressure off the machine and may cause unnecessary damage to your driver.
- When the post is at the desired depth, fully release the throttle trigger and gently slide the machine off the post. Move to the next post and repeat the above procedure. **ALWAYS** fully release the throttle trigger to stop the hammer action prior to removing from the post. You can leave the engine idling, there is no need to repeatedly turn the engine on and off.



## Refueling

- Always turn the engine off and allow adequate time for it to cool before refueling. **ONLY USE UNLEADED FUEL WITH 86 OCTANE OR HIGHER.**
- **NEVER** refuel your driver with the engine hot, running, or in an unventilated area. Fuel vapors are extremely flammable and can cause severe injury or death if ignited by a spark or excessive heat from a hot engine.
- Fill the tank on level ground and avoid spilling the fuel on the motor. Always allow any spilled fuel to evaporate before restarting the engine.
- Ensure the fuel cap is adequately tightened before restarting the engine.

## Installing the Adapter Sleeve

- A 1" adapter sleeve is included with each PGD2000 Post Driver and a 2" adapter sleeve is included with each PGD3200 Post Driver.
- To install the adapter sleeve, simply press the narrow end of the reducer sleeve into the barrel.
- For ease of inserting/removing, only use half of the rubber pads with your reducer sleeve. For the most secure fit, use all eight rubber pads with your reducer sleeve.
- Additional sleeve sizes are available for both the PGD2000 and PGD3200 Post Drivers.

# Service and Maintenance

The Titan Gas-Powered Post Driver has been manufactured and designed to give you years of trouble-free post driving. Always refer to the Honda GX35 manual for service and maintenance guidelines on your engine. The following maintenance guidelines will keep your machine in top-performing condition.

Be sure to properly store your Titan Post Driver. **DO NOT** lay it horizontally on the driver side or resting on the engine. The recommended method of storing is in an upright position, however, if this is not possible, place it on a flat surface with the barrel and brush-guard supporting the machine at an angle, so that the top handle is the highest point.

**If you are experiencing an issue with the Honda engine, please contact your local Honda dealer for parts and service. Titan Post Drivers does not carry the engine parts for Honda, nor does Titan Post Drivers determine the warranty, which is honored by Honda.**

## Before each use:

1. Check the engine oil level by holding the machine in an upright position. Lying the machine down to check the oil will give you a false reading. Use SAE 10W-30 oil to top off if necessary.
2. Check the engine air filter. If it is overly soiled, clean or replace it.
3. Check all post driver fasteners and retighten if necessary. If you choose to reinstall any bolts with new Loctite, you must clean the bolt and the area of the bolt hole with parts cleaner to remove any grease residue. The Loctite will not be effective if grease is present. Follow any torque requirements.
4. Visually check the inside of the barrel and the anvil for any debris or foreign objects.
5. Check for any fluid leaks.

## First 10 hours use:

1. Change the engine oil following the guidelines in your Honda GX35 manual. Dispose of discarded oil in accordance with all local, state, and federal regulations. **DO NOT OVERFILL.** Always check the oil level by holding the machine in an upright position.
2. Check all engine and post driver fasteners and retighten if necessary. If you choose to replace or reinstall any bolts with new Loctite, follow the guidelines listed above pertaining to Loctite. Follow any torque requirements.
3. **CHECK GREASE:** For continuous, hard pounding and/or when the driver body is hot to the touch, check the grease level of your driving in the following manner:
  - i Remove the crank housing cover to check the EP 0 grease level. The crank area should look clean and grease should be visible around the crank area and on top of the piston. There should be a ring of grease collected against the wall of the crank case.
  - ii If the ring of grease around the crank case wall measures less than  $\frac{1}{4}$ " , it is an indication that the grease level is low. Add no more than a few tablespoons of TITAN EP 0 grease (NON-APPROVED GREASE TYPES WILL CAUSE THE MACHINE TO NOT OPERATE CORRECTLY AND WILL VOID YOUR WARRANTY). You never want to exceed  $\frac{1}{2}$ " of grease ring around the crank case

walls. **DO NOT OVERFILL THE CRANK CASE WITH GREASE.** This can damage the driver and Honda engine. See Figure 3.



*Figure 3: Grease ring example*

- iii If the grease is very dark or black in color or full of debris, the driver will require further maintenance as detailed in the *Servicing of the Hammer and Anvil* section of this manual.
- iv In the event of complete removal of old grease, the level of the fresh, new grease should be to the bottom of the crank pin (approximately 3-4 tablespoons). See Figure 4.



*Figure 4: New grease example (before any single use)*

### Every 10 hours of use:

1. Check the grease level of the driver as described in Step 3 of the *First 10 Hours Use* guidelines.

### Every 3 months or 25 hours of use:

1. Change the engine oil following the guidelines in your Honda GX35 manual. Dispose of discarded oil in accordance with all local, state, and federal regulations. **DO NOT OVERFILL.**
2. Replace air filter. This should be performed more often if your post driver is operated in dusty conditions.
3. Check all engine and post driver fasteners and retighten if necessary. If you choose to replace or reinstall any bolts with new Loctite, follow the guidelines listed above pertaining to Loctite. Follow any torque requirements.

### Every 12 months or 250 hours of use:

1. Follow the above regularly scheduled maintenance guidelines for every 3 months or 25 hours of use.
2. Follow the above regularly scheduled maintenance guidelines for every 4 months or 50 hours of use.
3. Remove and service the hammer and anvil according to guidelines in the *Servicing of Hammer and Anvil* section.
4. Replace all O-rings and housing seals. A rebuild kit including all the Viton O-rings, seals, grease, and Loctite is available from Titan Post Drivers.

The amount and type of grease used in your Titan Post Driver is critical for the performance and service life of your post driver. Not enough grease will cause failure, and too much grease will overburden the piston and affect the hammering power of the machine. Use only Titan-approved EP 0 grease, which is available from Titan Post Drivers.

**ALWAYS** reassemble your driver fasteners using **LOCTITE BLUE 243**. Remember to clean the fastener and the holes with a parts cleaner to remove all grease residue, or the Loctite will not be effective.

If you are unsure of anything in this manual, please contact Titan Post Drivers directly at (702) 293-4262.

If you are experiencing performance issues with your Titan Gas-Powered Post Driver, please refer to the *Troubleshooting* section of this manual for possible solutions or contact Titan Post Drivers for assistance.

# Servicing of Hammer and Anvil (Rebuild)

## Bottom Driver Body

- Wear eye protection.
- Remove the 6 bolts on the bottom half of the lower driver body. Be aware that the handle tubes have anti-vibration springs that are installed under tension. The damper assembly washer will sometimes be removed with the lower driver body, or it may remain in place in the upper driver body.
- Remove the damper section and inspect the rubber O-rings and steel components for wear or debris. Take notice of the orientation of the damper assembly parts, as they must be oriented the same way when reinstalled.
- Remove the anvil (hammer that hits the post). Locate the Viton O-ring and replace it at this time.  
The anvil is made of high-quality, hardened-tool steel and should not show any signs of wear. Thoroughly clean the anvil. See Figures 5 and 6.



**Figure 5: View when lower driver body is removed**



**Figure 6: Damper assembly, hammer and anvil.**

## Top Driver Body

- Wear eye protection.
- To remove the hammer, gently tap the main cast housing vertically down on a soft bench top, and it should slide out of the barrel. Locate the Viton O-ring and replace it at this time. The hammer is made of high-quality, hardened-tool steel and should not show any signs of wear. Thoroughly clean the hammer.
- To remove the piston and connecting rod, you will need to remove the **LEFT-HAND THREAD** crank pin from the crank, and gently push the piston through the bottom of the housing. To access the crank pin, remove the crank housing cover. Use caution when handling the connecting rod and crankshaft as to not damage these components.
- Clean and inspect the piston and connecting rod. Insert the crank pin into the bearing on the connecting rod to check for fit. If there is excessive play or side-to-side movement, you may need to replace the crank pin. Check the movement in the bearing on the piston side. If there is excessive play, the connecting rod should be replaced. Locate the Viton O-ring on the piston and replace it at this time. See Figures 7 and 8.

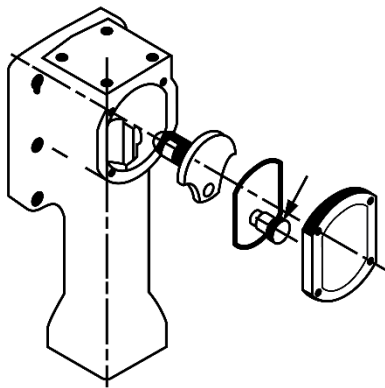

**Figure 7: Location of left-hand thread crank pin**

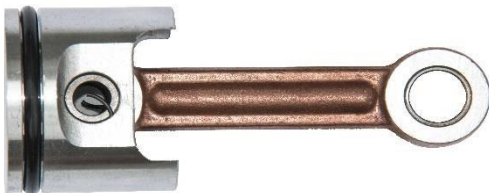

**Figure 8: Piston with connecting rod in place**

- Clean and inspect the cylinder and crank case for any damage or excessive wear. Replace any damaged parts you may identify.
- Remove the inner springs of the handle to clean and lubricate each one. Check all handle cups for any excessive wear. Clean and lubricate the upper and lower cups.

# Reassembly

After thoroughly cleaning and drying the hammer components and the cylinder, reassembly can be done.

1. Wear eye protection.
2. Apply a wipe of EP 0 grease around the O-ring and outside of the piston, and gently push it back into the housing. Be careful not to score any metal parts.
3. Add a small amount of EP 0 grease to the crank pin shoulder and reassemble. Be careful to keep grease off the crank pin threads. Remember it is left-hand thread. Torque the crank pin to 228 inch-pounds. **DO NOT OVERTIGHTEN THIS PIN.**
4. Add a wipe of EP 0 grease to the outside of the hammer and gently push it into the housing with the O-ring toward the top.
5. For the anvil section, add a wipe of EP 0 grease to the anvil, and push the anvil into the guide tube.
6. Reassemble the damper assembly, adding a small amount of EP 0 grease to all components. The hammer guide ring should be oriented correctly so the side with the large chamfer (slightly rounded/sloped edge) is facing down toward the anvil. Remember, "*round to the ground*". See Figure 9.



**Figure 9: View of the orientation of internal parts**

7. Install the metal damper washer back over the anvil.
8. Install the bottom guide section back into the main housing. Be sure to install the new bottom housing O-ring.
9. Insert the anti-vibration springs back into the handlebars and reinstall them into the upper and lower handle cups. When parts are inserted correctly, there will be resistance from the springs to seat the lower driver body. This is normal.
10. Reinstall the bottom housing bolts with new Loctite. You must clean the bolt and the area of the bolt hole with parts cleaner to remove any grease residue. The Loctite will not be effective if grease is present. Torque these bolts to 132 inch-pounds.

11. Add approximately 4 tablespoons of new EP 0 grease to the crank area and reinstall the crank cover bolts with new Loctite. You must clean the bolt and the area of the bolt hole with parts cleaner to remove any grease residue. The Loctite will not be effective if grease is present.

All screws should be correctly tightened in an alternate pattern as machine damage will occur from loose or lost bolts due to improper installation.

Please contact Titan Post Drivers directly at (702) 293-4262 if you need parts or have any servicing questions.



# Troubleshooting

1. If your driver sounds like it is running fine, but the anvil is not hammering as it should, make sure your anvil is fully engaged. There is a safety that will disengage the anvil if it is dry-fired or misfired. To re-engage the anvil, simply pick the driver up off the post, and place it back down on the post with a bit of force to hit the anvil against the post. **AVOID REPEATED DRY-FIRE** by maintaining 10-12 pounds of down-pressure at all times.
2. Check the type of grease in the crank. **REPAIR/SERVICE ONLY WITH TITAN EP 0 GREASE.** EP 0 is a low-viscosity grease for machinery with rapid moving parts that produce a lot of friction. If you use a different type of grease, you will inhibit the performance of your driver and possibly cause damage to your driver or your engine. If you have greased your driver with the wrong grease, you will need to follow the instructions in the *Service and Maintenance* section of this manual for replacing grease in the crank housing area.
3. Check the amount of grease in the crank case. If your driver is over-greased, it will cause reduced performance of the machine and put undue stress on the engine and the operations of the gears and piston in the machine. There should be approximately 4-5 tablespoons of grease visible in the crank housing. There must be room for free movement of the parts.
4. If your driver is low on grease, it will cause reduced performance of the machine. Open the crank housing cover to visually check the amount of grease in your driver. You should always see a bit of grease residue moving throughout the machine. You may even see grease left on the posts. This is a good thing. It means your machine is self-lubricating.
5. If you feel that the anvil or hammer of the machine is not moving as freely as it should, you can spray penetrating oil up into the barrel to lubricate and cleanse this area. Occasionally you will get bits of debris that chip off the posts and make their way up into the anvil area. This may require disassembly to clean.
6. If your engine seems to be overheating and not operating as it should, clear any debris has built up around the engine, specifically the air filter. If that does not resolve the issue, there may be fuel system pressure buildup. You can verify this by unscrewing the gas cap and listening for a rush of air. If you hear a rush of air, pressure has built up. Check the breather of the gas cap and clear it if clogged.
7. In the event that a driven post flares and becomes lodged within the barrel, follow these steps:
  - A. Remove the 6 lower body bolts to separate the lower driver body from the upper driver body.
  - B. Slide the lower driver body down the post to expose the flared top of the post. With a proper cutting tool for that type of post, cut the post off just below the flared top.
  - C. Once the flared top is removed, slide the lower driver body off the post and reassemble it to the upper driver body. Follow the bolt tightening and Loctite guidelines explained in the *Reassembly* section of this manual.
  - D. **IF YOU ARE USING A REDUCERSLEEVE**, pull the driver free from the reducer sleeve, leaving the reducer sleeve on the post. With a proper cutting tool for that type of post, cut the post off just below the flared top. Remove the reducer sleeve from the post and reinstall the sleeve.

8. If you are having difficulties starting your driver, disconnect the leads between the throttle switch and the engine. Retry the *Safe Starting* procedure in the *Operating Instructions* section of this manual. If the engine starts easily, the throttle switch may be unintentionally grounding out and need maintenance/replaced. Otherwise, there may be an issue with the Honda engine.

If you are experiencing an issue with the Honda engine, please contact your local Honda dealer for parts and service. Titan Post Drivers does not carry the engine parts for Honda, nor does Titan Post Drivers determine the warranty, which is honored by Honda.

If these steps do not address your issue, call Titan Post Drivers at (702) 293-4262 for further assistance.

# Warranty

Titan Post Drivers will warrant to the original purchaser, who purchases the equipment in new condition and in its original packaging from an authorized dealer, that its gas-powered post driver will be free from defects in workmanship and materials for a period of one (1) year. This warranty period will commence on the date of retail purchase by the original purchaser. Titan Post Drivers provides no warranty on the Honda engine. This warranty is provided directly by Honda for a period of one (1) year commercial use or two (2) years normal use, and will be honored at any local Honda dealer. Both the Titan Post Drivers warranty and the Honda warranty are non-transferrable beyond the original purchaser.

- To register your Titan Post Driver, go to <https://www.titanpostdrivers.com/warranty-registration/> and fill out the warranty registration form.
- Warranty shall pertain to parts or service offered by an authorized Titan Post Drivers dealer. Any defective part replaced at an authorized Titan Post Drivers location becomes the property of Titan Post Drivers.
- Shipping costs to transport the machine to and from the service center for warranty work will be the responsibility of the consumer.
- For warranty claims, contact Titan Post Drivers with proof of purchase date and your serial number.

## Limitations of Warranty

This limited warranty does not extend to any Titan Post Drivers product which has been misused, abused, or improperly maintained, altered, or repaired by an unauthorized person. Nor does this limited warranty cover any damage to machine or parts due to faulty installation of parts, faulty operation, or faulty maintenance.

- Damage to components caused by operator error such as dry-fire or misfire will not be considered for warranty replacement or service.
- Damage to cosmetic parts caused by rough handling, operator error, or improper storage and handling will not be considered for warranty replacement or service.
- Excluded components may need replacement or repair due to normal wear and tear, or lack of proper use/maintenance include:
  1. O-rings and seals
  2. Lost or stripped fasteners
  3. Barrel of driver from incorrect use of machine
  4. Crank pin that is broken from incorrect handling (left-hand thread)
  5. Titan Post Drivers sleeves/accessories

## Disclaimer of Warranty

Titan Post Drivers disclaims all liability for any implied warranties. Under no circumstances shall Titan Post Drivers be liable for any loss of business, revenues, profit, or indirect, incidental, special, or consequential damages or loss arising out of any defect in, or performance of, Titan Post Drivers products, howsoever caused. For warranty terms on your Honda GX35 engine, please refer to the separate warranty in the Honda manual provided with your post driver.

Titan Post Drivers is an authorized Honda OEM for use of Honda brand engines on our products. Titan PGD2000 and PGD3200 post drivers have undergone and passed the testing requirements for the engines to be warranted directly by any authorized Honda dealer. You can find a local dealer here: <http://engines.honda.com/dealer-locator>.



Your Titan Gas-Powered Post Driver has a one-year warranty, with a limited lifetime warranty on the hammer. Please refer to your operator's manual for complete warranty details.

*You MUST complete this registration within 30 days of purchase for the warranty to be valid. Warranty is non-transferrable.*

**Name:** \_\_\_\_\_

**Driver Serial Number:** \_\_\_\_\_ **Engine Serial Number:** \_\_\_\_\_

**Place of Purchase:** \_\_\_\_\_ **Date of Purchase:** \_\_\_\_\_

Visit us online at [www.titanpostdrivers.com/pages/registration](http://www.titanpostdrivers.com/pages/registration) to complete your warranty registration. Or, scan the QR code to complete your warranty registration on your mobile device.



**Date of Completion:** \_\_\_\_\_

Complete and keep this card for your records.  
Your Honda engine can be serviced at any Honda dealer with proof of purchase.

## Contact Info:

**Hours:** Monday-Friday 8 AM to 5 PM CST

**Address:** 713 E Austin Blvd, Nevada, MO 64772

**Phone:** (702) 293-4262

**Email:** [info@titanpostdrivers.com](mailto:info@titanpostdrivers.com)

# PGD2000/3200 Parts Diagram

1 of 2

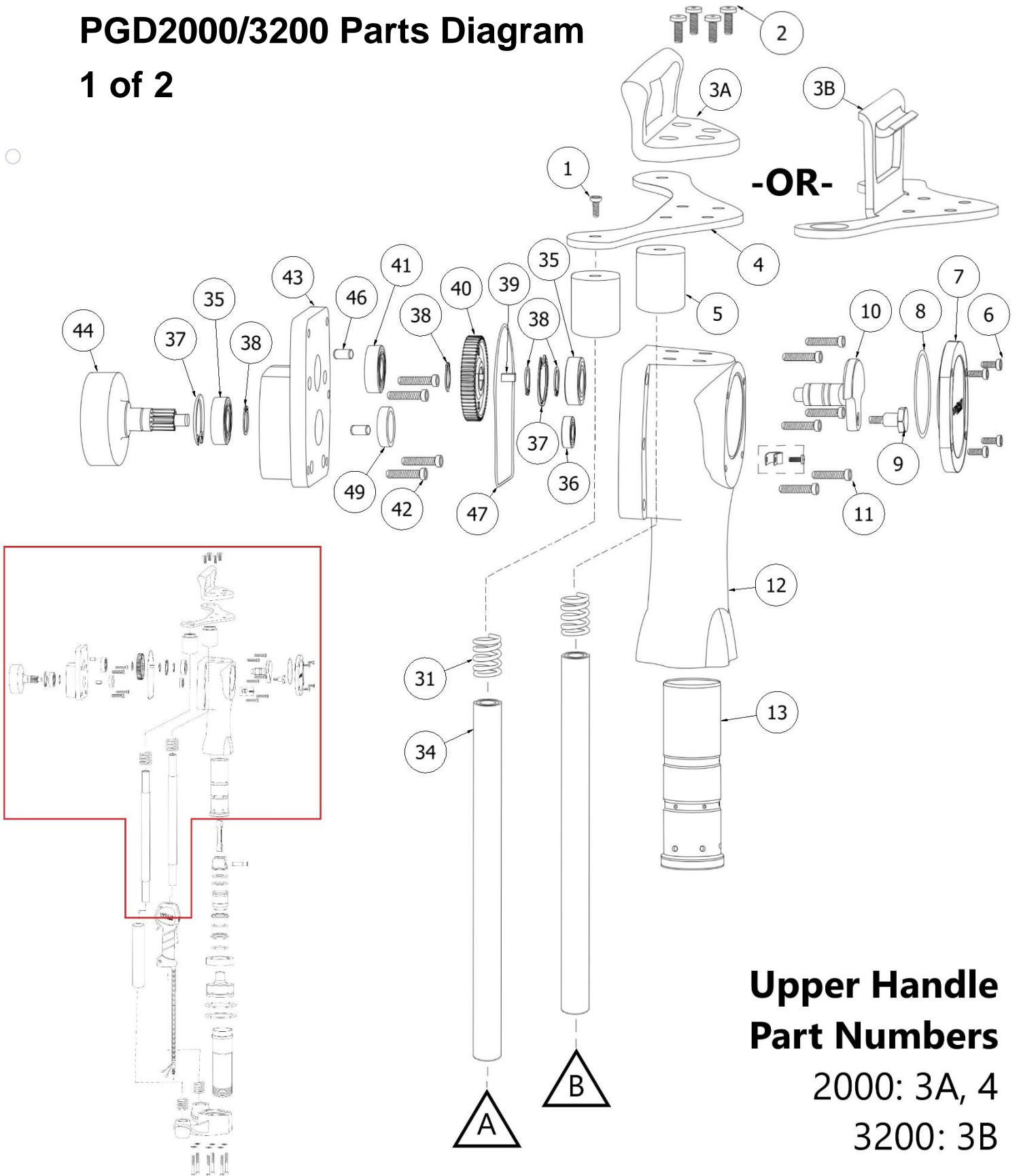

## Upper Handle Part Numbers

2000: 3A, 4

3200: 3B

# PGD2000/3200 Parts Diagram

2 of 2

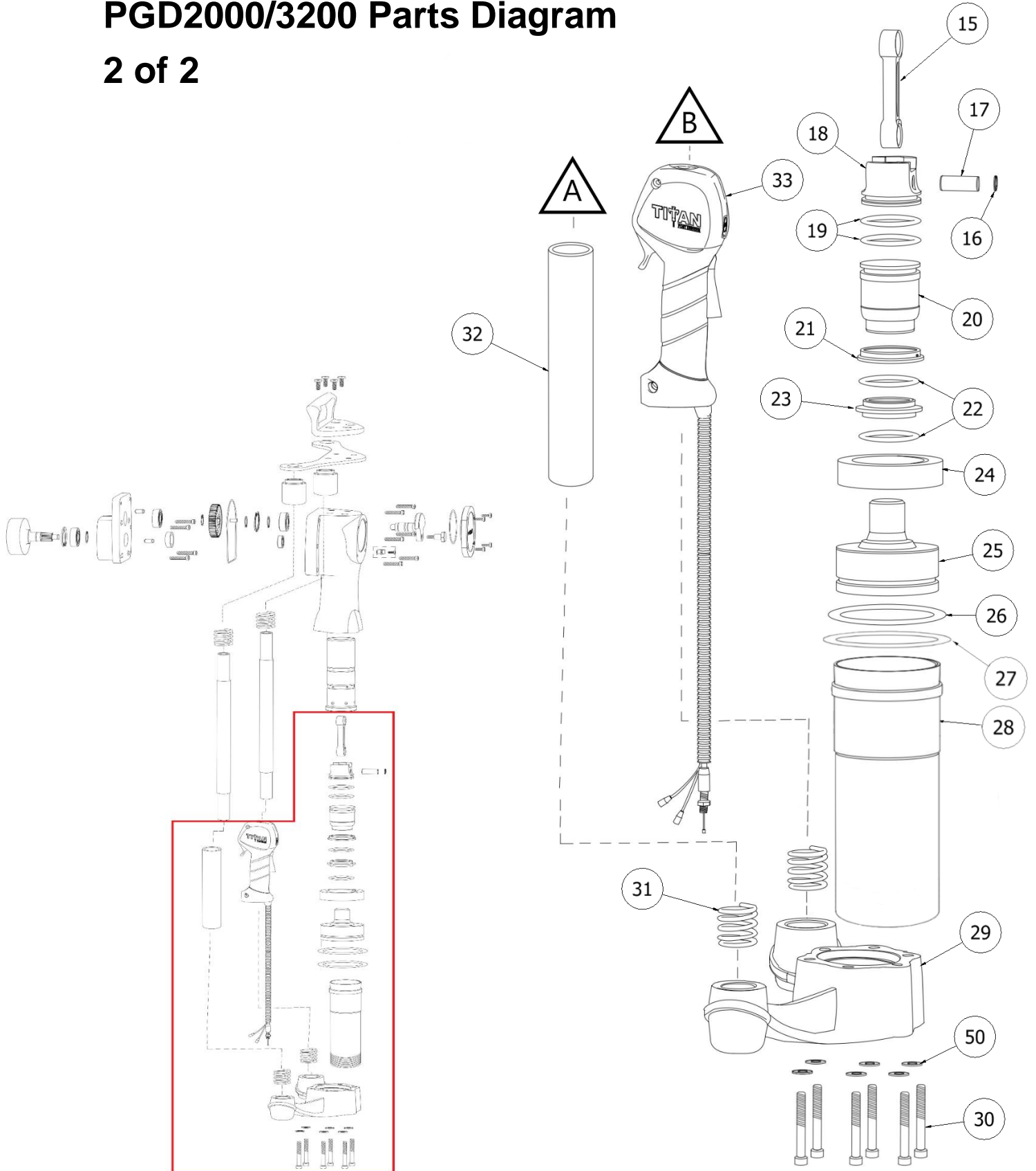

# PGD2000 Parts List

SERVICE ITEMS AVAILABLE SEPARATELY			
KEY	SERVICE CODE	DESCRIPTION	QTY
3A	YPGD3	UPPER HANDLE	1
4	YPGD4	FIXED PLATE	1
5	YPGD5	HANDLE CUP	2
28	YPGD28-1	CHUCK TUBE	1
29	YPGD29	LOWER DRIVER BODY	1
31	YPGD31	HANDLE ANTI-VIBRATION SPRING	4
32	YPGD32	HANDLE CUSHION	1
33	YPGD33X	THROTTLE SWITCH	1
34	YPGD34	HANDLE TUBE	2
40	YPGD40	MAIN GEAR	1
46	YPGD46	ALIGNMENT PIN 8x15	2
47	YPGD47-1	GASKET CLUTCH TO BODY	1
51	PGDRS##-1	REDUCER SLEEVE	1
		MULTIPLE SIZES AVAILABLE	
-	PGDLUBE	TITAN EP 0 GREASE, 4oz	1

HARDWARE KIT SERVICE CODE: PGDHDWKIT		
KEY	DESCRIPTION	QTY
1	M8x15 BUTTON HEAD CAP SCREW	2
2	M8x20 BUTTON HEAD CAP SCREW	4
6	M5x15 SOCKET HEAD CAP SCREW	4
11	M6x30 SOCKET HEAD CAP SCREW	6
42	M6x30 SOCKET HEAD CAP SCREW W/ WASHER	4
30	M8x60 SOCKET HEAD CAP SCREW	6
50	M8 NORDLOCK WASHER PAIR	6

O-RING REBUILD KIT SERVICE CODE: PGD2000RKIT		
KEY	DESCRIPTION	QTY
8	O-RING 76x2.65 NITRILE	1
19	O-RING 37.5x3.5 VITON	2
22	O-RING 40x5.3 VITON	2
26	O-RING 45x3.5 VITON	1
27	O-RING 56x2.65 NITRILE	1
-	BLUE THREADLOCK, 0.5mL	1
-	TITAN EP 0 GREASE, 4oz	1

CLUTCH ASSEMBLY SERVICE CODE: YPGDWCHKIT		
KEY	DESCRIPTION	QTY
35	6004-2RS BEARING	1
37	42MM SNAP RING	1
38	20MM SNAP RING	1
41	6201-2RS BEARING	1
43	CLUTCH HOUSING	1
44	CLUTCH DRUM	1
47	GASKET CLUTCH TO BODY	1
49	OIL SEAL	1

CRANK ASSEMBLY SERVICE CODE: PGDCRKIT		
KEY	DESCRIPTION	QTY
9	CRANK PIN	1
10	CRANK SHAFT	1
35	6004-2RS BEARING	1
36	6000-2RS BEARING	1
37	42MM SNAP RING	1
38	20MM SNAP RING	3
39	KEY 6x6x12	1
47	GASKET CLUTCH TO BODY	1

DRIVER PISTON ASSEMBLY SERVICE CODE: PGDWDPKIT		
KEY	DESCRIPTION	QTY
15	CONNECTING ROD	1
16	12MM RETAINER	2
17	WRIST PIN 12x32	1
18	PISTON	1
19	O-RING 37.5x3.5 VITON	1

HAMMER/ANVIL ASSEMBLY SERVICE CODE: PGDWHAKIT		
KEY	DESCRIPTION	QTY
20	HAMMER	1
21	DAMPER WASHER	1
23	DAMPER GUIDE RING	1
24	DAMPER CUP	1
25	ANVIL	1
19	O-RING 37.5x3.5 VITON	1
22	O-RING 40x5.3 VITON	2
26	O-RING 45x3.5 VITON	1

BODY WITH INSERTED CYLINDER SERVICE CODE: PGDWBSKIT		
KEY	DESCRIPTION	QTY
12	POST DRIVER BODY	1
13	CYLINDER	1

# PGD3200 Parts List

SERVICE ITEMS AVAILABLE SEPARATELY			
KEY	SERVICE CODE	DESCRIPTION	QTY
3B	YPGD3M	UPPER HANDLE W/ FIXED PLATE	1
5	YPGD5	HANDLE CUP	2
28	YPGD28M	CHUCK TUBE	1
29	YPGD29M	LOWER DRIVER BODY	1
31	YPGD31	HANDLE ANTI-VIBRATION SPRING	4
32	YPGD32	HANDLE CUSHION	1
33	YPGD33X	THROTTLE SWITCH	1
34	YPGD34	HANDLE TUBE	2
40	YPGD40	MAIN GEAR	1
46	YPGD46	ALIGNMENT PIN 8x15	2
47	YPGD47-1	GASKET CLUTCH TO BODY	1
51	PGDRSM##	REDUCER SLEEVE	1
		MULTIPLE SIZES AVAILABLE	
-	PGDLUBE	TITAN EP 0 GREASE, 4oz	1

HARDWARE KIT SERVICE CODE: PGDHDWKIT		
KEY	DESCRIPTION	QTY
1	M8x15 BUTTON HEAD CAP SCREW	2
2	M8x20 BUTTON HEAD CAP SCREW	4
6	M5x15 SOCKET HEAD CAP SCREW	4
11	M6x30 SOCKET HEAD CAP SCREW	6
42	M6x30 SOCKET HEAD CAP SCREW W/ WASHER	4
30	M8x60 SOCKET HEAD CAP SCREW	6
50	M8 NORDLOCK WASHER PAIR	6

O-RING REBUILD KIT SERVICE CODE: PGD3200RKIT		
KEY	DESCRIPTION	QTY
8	O-RING 76x2.65 NITRILE	1
19	O-RING 42.5x3.8 VITON	2
22	O-RING 44x5.3 VITON	2
26	O-RING 78x3.8 VITON	1
27	O-RING 92x2.65 NITRILE	1
-	BLUE THREADLOCK, 0.5mL	1
-	TITAN EP 0 GREASE, 4oz	1

CLUTCH ASSEMBLY SERVICE CODE: YPGDMCHKIT		
KEY	DESCRIPTION	QTY
35	6004-2RS BEARING	1
37	42MM SNAP RING	1
38	20MM SNAP RING	1
41	6201-2RS BEARING	1
43	CLUTCH HOUSING	1
44	CLUTCH DRUM	1
47	GASKET CLUTCH TO BODY	1
49	OIL SEAL	1

CRANK ASSEMBLY SERVICE CODE: PGDCRKIT		
KEY	DESCRIPTION	QTY
9	CRANK PIN	1
10	CRANK SHAFT	1
35	6004-2RS BEARING	1
36	6000-2RS BEARING	1
37	42MM SNAP RING	1
38	20MM SNAP RING	3
39	KEY 6x6x12	1
47	GASKET CLUTCH TO BODY	1

DRIVER PISTON ASSEMBLY SERVICE CODE: PGDMDPKIT		
KEY	DESCRIPTION	QTY
15	CONNECTING ROD	1
16	12MM RETAINER	2
17	WRIST PIN 12x32	1
18	PISTON	1
19	O-RING 42.5x3.8 VITON	1

HAMMER/ANVIL ASSEMBLY SERVICE CODE: PGDMHAKIT		
KEY	DESCRIPTION	QTY
20	HAMMER	1
21	DAMPER WASHER	1
23	DAMPER GUIDE RING	1
24	DAMPER CUP	1
25	ANVIL	1
19	O-RING 42.5x3.8 VITON	1
22	O-RING 44x5.3 VITON	2
26	O-RING 78x3.8 VITON	1

BODY WITH INSERTED CYLINDER SERVICE CODE: PGDMBSKIT		
KEY	DESCRIPTION	QTY
12	POST DRIVER BODY	1
13	CYLINDER	1