

General Electric Advanced Technology Manual

Chapter 6.2

Primary Containments

TABLE OF CONTENTS

6.2	PRIMARY CONTAINMENTS	1
6.2.1	Introduction.....	1
6.2.2	Mark I Containment	1
6.2.2.1	Component Description	2
6.2.2.2	Containment Response to a LOCA	6
6.2.3	Mark II Containment	7
6.2.3.1	Component Description	7
6.2.3.2	Containment Response to a LOCA	12
6.2.4	Mark III Containment	13
6.2.4.1	Component Description	14
6.2.4.2	Containment Response to a LOCA	16
6.2.5	Refueling	18
6.2.5.1	Mark I and II	18
6.2.5.2	Mark III	20
6.2.6	Summary	23

LIST OF TABLES

Table 6.2-1	Containment Comparison Chart	24
-------------	------------------------------------	----

LIST OF FIGURES

- 6.2-1 Mark I Containment
- 6.2-1a Mark I Reactor Building
- 6.2-2 Mark I Containment Combustible Gas Control
- 6.2-3 Mark II Containment
- 6.2-4 Mark II Containment Combustible Gas Control
- 6.2-5 Mark III Containment
- 6.2-6 Mark III Horizontal Vent Arrangement
- 6.2-7 Mark III Containment Combustible Gas Control
- 6.2.8 Mark I and II Refuel Floor
- 6.2.9 Mark III Refuel Floor
- 6.2.10 Mark III Reactor Building and Fuel Building Elevation
- 6.2.11 Mark III Inclined Fuel transfer System (IFTS)

6.2 PRIMARY CONTAINMENTS

Learning Objectives:

1. Recognize the component differences of the Mark I, Mark II and Mark III containments.
2. Identify how the three containment types respond to a LOCA.
3. Identify how post-accident containment atmosphere (hydrogen and/or oxygen) is controlled for each BWR containment type.

6.2.1 Introduction

The primary containment package provided for a particular product line is dependent on the vintage of the plant and the cost-benefit analysis at the time of construction. During the evolution of the Boiling Water Reactor, three major types of containments were built. The major containment designs are the Mark I, Mark II, and Mark III. Unlike the Mark III, that consists of a primary containment and a drywell, the Mark I and Mark II designs consist of a drywell and wetwell (suppression chamber). All three primary containment designs use the principle of pressure suppression for loss of coolant accidents. For comparison of containments see Table 6.2-1.

Each of the containment designs performs the same functions:

- Condenses steam and contains fission products released from a LOCA so that the offsite radiation doses specified in 10 CFR 100 are not exceeded.
- Provides a heat sink for certain safety related equipment.
- Provides a source of water for emergency core cooling systems and the Reactor Core Isolation Cooling (RCIC) system.

6.2.2 Mark I Containment

The Mark I containment design consists of several major components, many of which can be seen in Figure 6.2-1. These major components include the drywell, which surrounds the reactor vessel and recirculation loops; a suppression chamber, which stores a large body of water (the suppression pool); and an interconnecting vent network between the drywell and the suppression chamber. Additionally, there are numerous auxiliary systems associated with the primary containment that are required to meet its intended function.

6.2.2.1 Component Description

The major components of the primary containment system are discussed in the paragraphs that follow.

Drywell

The purposes of the drywell are to contain the steam released from a loss of coolant accident (LOCA) and direct it to the suppression chamber, and to prevent radioactive materials from passing through its portion of the primary containment boundary.

The drywell is a steel pressure vessel with a spherical lower portion and cylindrical upper portion. The top head closure is made with a double tongue and groove seal which permits periodic checks for tightness without pressurizing the entire vessel. Bolts secure the drywell head to the cylindrical section during conditions that require primary containment integrity.

Some Mark I drywells are free standing. At other Mark I containments the drywell is enclosed by reinforced concrete for shielding and for additional resistance to deformation and buckling over areas where the concrete backs up the steel shell. Above the foundation for reinforced drywells, the drywell is separated from the reinforced concrete by a gap of approximately two inches for thermal expansion. All Mark I drywells are vertically and laterally supported by a concrete basemat.

Shielding over the top of the drywell is provided by removable, segmented, reinforced concrete shield plugs. In addition to the drywell head, one double door personnel air lock and two bolted equipment hatches are provided for access to the drywell.

Suppression Chamber

The suppression chamber consists of a steel pressure vessel with a toroidal shape (sometimes referred to as a torus) and a large body of water inside the suppression chamber (referred to as the suppression pool).

The purposes of the suppression pool are as follows:

- to serve as a heat sink for LOCA blowdown steam
- to prevent radioactive materials from passing through this portion of the primary containment boundary.
- to serve as a heat sink for safety/relief valve discharge steam
- to serve as a heat sink for High Pressure Coolant Injection (HPCI) system and Reactor Core Isolation Cooling (RCIC) system turbine exhaust steam
- to provide a source of water for the Low Pressure Coolant Injection (LPCI) mode of the Residual Heat Removal (RHR) system, Core Spray (CS) system, HPCI system, and RCIC system.

The suppression chamber is located radially outward and downward from the drywell and is held on supports which transmit vertical and seismic loading to the reinforced foundation slab of the reactor building.

Access to the suppression chamber is provided through two manways with double gasket bolted covers. These access ports (manways) are bolted closed when primary containment integrity is required and can be opened only when primary coolant temperature is below 212°F and the pressure suppression system is not required to be operational.

Interconnecting Vent System

The interconnecting vent network is provided between the drywell and suppression chamber to channel the steam and water mixture from a LOCA, to the suppression pool and allow noncondensable gases to be vented back to the drywell. Eight large vent pipes (about 81" in diameter) extend radially outward and downward from the drywell into the suppression chamber. Inside the suppression chamber the vent pipes exhaust into a toroidal vent header which extends circumferentially all the way around the inside of the suppression chamber. Extending downward from the vent header are ninety six downcomer pipes which terminate about three feet below the suppression pool minimum water level. Jet deflectors are provided in the drywell at the entrance to each vent pipe to prevent possible damage to the vent pipes from jet forces which might accompany a line break in the drywell. The vent pipes are provided with expansion joints to accommodate differential motion between the drywell and suppression chamber.

Vacuum Relief System

There are two vacuum relief networks associated with preventing the primary containment from exceeding the design external pressure of 2 psi. The first vacuum relief network consists of a set of twelve self actuating swing check valves. These suppression chamber-to-drywell vacuum relief valves vent noncondensable gases from the suppression chamber to the drywell whenever suppression chamber pressure exceeds drywell pressure by 0.5 psid. Venting noncondensable gasses back to the drywell helps prevent the dynamic forces from "chugging" as steam enters the suppression chamber.

The second vacuum relief network consists of a set of two vacuum relief lines from the reactor building (secondary containment) to the suppression chamber. Each line contains a self actuated check valve and an air operated butterfly type vacuum breaker in series. These reactor building to suppression chamber vacuum relief lines vent air from the reactor building to the suppression chamber whenever reactor building pressure exceeds suppression chamber pressure by 0.5 psid. The vacuum breakers prevent a large differential pressure from imploding the containment. Venting reactor building air

into the suppression chamber adversely affects containment inerting.

The suppression chamber-to-drywell vacuum breakers are remotely tested by using air cylinder actuators. Testing of the suppression chamber to reactor building vacuum breakers is accomplished by testing the equipment which automatically opens the air operated butterfly valves and manually exercising the check valves.

Drywell Cooling System

During normal plant operation there is a closed atmosphere within the drywell and the suppression chamber. Since the reactor vessel is located within the drywell, heat must be continuously removed from the drywell atmosphere. Drywell temperature is maintained <135°F by operating drywell cooling units. Each cooling unit consists of a motor driven fan which blows the existing drywell atmosphere (either nitrogen gas or air) past a heat exchanger which is cooled by the reactor building closed cooling water (RBCCW) system or a chilled water system.

Primary Containment Ventilation System

The purpose of the primary containment ventilation system is to allow for influent air to be brought into the drywell and suppression chamber and for effluent atmosphere to be discharged from the drywell and suppression chamber. This system uses connections to the reactor building heating, ventilation, and air conditioning (HVAC) system for influent air. Connections to the reactor building via the primary containment purge system and to the standby gas treatment system (SGTS) are used for effluent atmosphere. The reactor building HVAC system is used to supply filtered and temperature controlled outside air to the primary containment for air purge and ventilation purposes to allow for personnel access and occupancy during reactor shutdown and refueling operations. The purge exhaust air is either removed by the primary containment purge system and discharged to the atmosphere via the reactor building HVAC system exhaust fans or removed by the standby gas treatment system and discharged to the atmosphere via the plant stack. In either case the effluent is treated prior to release.

Containment Inerting System

The purpose of the containment inerting system is to create and maintain an inerted atmosphere of nitrogen gas inside the primary containment during normal plant power operation. It is necessary to inert the primary containment atmosphere with nitrogen gas in order to maintain the primary containment oxygen concentration less than 4%. Starting with an inerted atmosphere is important in preventing an explosive mixture of hydrogen and oxygen in the primary containment atmosphere following postulated loss of coolant accidents with postulated hydrogen generation.

The containment inerting system consists of a nitrogen (N₂) purge supply and a nitrogen

(N₂) makeup supply. The N₂ purge supply is used to initially create the inerted atmosphere in the primary containment. Nitrogen purge systems consist of a liquid nitrogen storage tank, a steam vaporizer (to convert liquid nitrogen to the gaseous state), and associated valving and piping to deliver nitrogen to the primary containment influent ventilation lines. Nitrogen gas is supplied to the primary containment through the purge supply at a rate of 3000-4500 scfm while primary containment atmosphere is discharged to the reactor building HVAC system exhaust ventilation duct or to the standby gas treatment system. This process continues until primary containment oxygen concentration is less than 4%, which takes approximately four hours and requires three to five containment atmosphere volumetric changes.

After the inerted atmosphere has been created, the nitrogen makeup supply is used to continue to supply nitrogen gas as required by temperature changes and leakage. The primary containment is held at a slight positive pressure by the makeup supply and uses the same liquid nitrogen storage tank, its own vaporizer, and valving and piping to deliver nitrogen gas at a rate of <60 scfh to the primary containment.

Containment Atmosphere Dilution System

The purpose of the Containment Atmosphere Dilution (CAD) system is to control the concentration of combustible gases in the primary containment subsequent to a loss of coolant accident with postulated high hydrogen generation rates. The CAD system is capable of rapidly supplying nitrogen gas at a rate sufficient to maintain the oxygen concentrations of both the drywell and suppression chamber atmospheres below 5% by volume based on the hydrogen generation rate associated with a 5% zirconium-water reaction due to high fuel cladding temperatures.

The CAD system nitrogen supply facilities shown in some detail in figure 6.2-2, include two separate trains, each of which is capable of supplying nitrogen through separate piping systems to the drywell and suppression chamber. Each train includes a liquid nitrogen supply tank, an ambient vaporizer, an electric heater, a manifold with branches to the primary containment; and pressure, flow, and temperature controls. The nitrogen storage tanks have a nominal capacity of 3000 gallons each which is adequate for the first seven days of CAD system operation. The nitrogen vaporizers use ambient atmosphere as the heat source. Electric heaters are provided for use during cold weather to warm the gas.

Following a LOCA, records are kept of hydrogen and oxygen concentrations and pressures in the drywell and suppression chamber. The CAD system is then operated manually to keep the oxygen concentration <5% or the hydrogen concentration <4% in each volume. Additions are made separately to the drywell and suppression chamber. Manual initiation of the CAD system is calculated to be required about 10 days following postulated design basis LOCA.

When the CAD system is adding nitrogen to the drywell and/or suppression chamber, pressure will increase. Before drywell pressure reaches 30 psig, drywell venting will be started. Gas releases will be performed periodically and independently from the drywell and suppression chamber.

Releases will be made during periods of the most favorable meteorological conditions at a rate of approximately 100 scfm until the desired volume has been released. Releases will continue over time until primary containment pressure has been reduced to atmospheric. Additions and releases will be conducted at different times.

6.2.2.2 Containment Response to a LOCA

When the postulated recirculation line break (DBA LOCA) occurs, the drywell is immediately pressurized. As drywell pressure increases, drywell atmosphere (primarily nitrogen gas) and steam are blown down through the radial vents to the vent header and into the suppression pool via the downcomers. The steam condenses in the suppression pool which suppresses the peak pressure realized in the drywell. Drywell pressure peaks at about 50 psig at about 10 seconds following the line break. Noncondensable gases discharged into the suppression pool end up in the free air volume of the suppression chamber which accounts for the suppression chamber pressure increase. As LOCA steam is condensed in the suppression pool, drywell pressure decreases and stabilizes 27 psig while suppression pool temperature reaches 135°F. Drywell pressure decreases to the point that suppression chamber pressure exceeds it by 0.5 psid. This causes the suppression chamber-drywell vacuum breakers to open and vent noncondensable gases back into the drywell to equalize the drywell and suppression chamber pressures.

Low pressure emergency core cooling systems (ECCS) begin pumping water into the reactor vessel, removing decay and stored heat from the core. Water injected into the reactor vessel then transports core heat out of the reactor vessel via the broken recirculation loop. The hot water collects on the drywell floor and then flows into the suppression chamber via the vent pipes, vent header, and downcomer pipes. Thus a closed loop is formed with low pressure ECCS pumps (core spray system and RHR system LPCI mode) pumping water from the suppression pool to the reactor vessel. The water then returns to the suppression pool and the process is repeated.

At about 600 seconds it is assumed that the RHR system would be switched from the LPCI mode to suppression pool cooling. In this mode suppression pool heat is removed via the RHR heat exchangers causing primary containment temperature and pressure to decrease. If necessary, the containment spray mode of the RHR system can be initiated to spray cooled suppression pool water into the drywell and/or suppression chamber atmospheres to control primary containment pressure.

6.2.3 Mark II Containment

The Mark II containment design consists of several major components, many of which can be seen in Figure 6.2-3. These major components include the drywell, which surrounds the reactor vessel and recirculation loops; a suppression chamber, which stores a large body of water (the suppression pool); and downcomers between the drywell and the suppression chamber. Additionally, there are numerous auxiliary systems associated with the primary containment that are required to meet its intended function.

6.2.3.1 Component Description

Drywell

The purposes of the drywell are to:

- contain the steam released from a LOCA
- direct LOCA leakage to the suppression chamber
- minimize radioactive material leakage from the primary containment boundary

The drywell (Figure 6.2-3) is a steel lined pressure vessel shaped in the form of a truncated cone. The top head closure is made with a double tongue and a groove seal which permits periodic checks for tightness without pressurizing the entire vessel. Bolts hold the top head in position when primary containment integrity is required to be maintained. The drywell is reinforced with concrete except where personnel airlocks, equipment hatches and the drywell head are located. The reinforcements provide additional shielding and resistance to deformation and buckling. Shielding over the top of the drywell is provided by removable, segmented, reinforced concrete shield plugs.

Seal assemblies are installed between the reactor vessel and primary containment and between the primary containment and fuel pool. These bellows type seals form a water tight barrier which permits flooding the volume above the reactor vessel during refueling operations.

One 7 ft diameter double door personnel air lock and a 10 ft diameter bolted equipment hatch are provided for access to the drywell. A smaller diameter personnel airlock is provided for emergency passage. The locking mechanisms on each air lock door are designed so that a tight seal will be maintained when the doors are subjected to internal pressure. The doors are mechanically interlocked so that one door may be operated only if the opposite door is closed and locked. Hand-wheels are provided inside and outside each end of the airlock which can be used to open or close either door. The door seals are designed to allow periodic testing for leakage. Access to the equipment hatch requires the removal of a concrete plug. The equipment hatch is bolted with a double seal arrangement.

Process piping and electrical lines that pass through the containment wall are fitted with

leak tight penetrations welded to the containment liner. Two types of process line penetrations are utilized. Hot process line penetrations are used for penetrations containing hot or variable temperature fluids that require thermal expansion capabilities. Cold process line penetrations are used for penetrations containing cold or relatively constant temperature fluids.

Primary containment isolation valves are provided on all process penetrations. The design function of those valves is to provide isolation of the containment in the event of an accident.

Suppression Chamber

The suppression chamber (Figure 6.2-4) consists of a right circular cylinder shaped steel pressure vessel which contains a large body of water called the suppression pool. The purposes of the suppression pool are as follows:

- minimize the release of radioactive materials from the primary containment boundary
- condense steam released from a LOCA
- serve as a heat sink for SRV discharge steam
- provide a source of water for the ECCSs and RCIC system
- serve as a heat sink for HPCI and RCIC turbine exhaust steam

The suppression chamber is located directly beneath the drywell. Vertical support and seismic loading is transmitted to the reinforced foundation slab of the reactor building. Design features of the suppression chamber are listed in Table 6.2-1. Access to the suppression chamber is provided through two 36 inch manways, each of which has a double gasket bolted cover. Both manways are normally bolted shut and are opened only during plant shutdown when primary containment is not required to be operational.

Providing a barrier between the drywell and the suppression chamber is the drywell floor. It is a circular reinforced concrete slab that is supported by the reactor pedestal and 14 concrete columns. Floor penetrations include 88 interconnecting downcomer vent pipes and 11 SRV tail pipes. The floor is designed to withstand a 30 psid downward differential pressure and a 5.5 psid upward differential pressure. Two circumferential floor seals are provided between the primary containment and drywell floor. Each seal is pressurized and maintained with 60 psig nitrogen supplied from the plant nitrogen supply system.

Interconnecting Vents

An interconnecting vent network is provided between the drywell and suppression chamber to channel the steam and water mixture from a LOCA to below the surface of the suppression pool. Eighty eight vent pipes (23.25" inside diameter) extend vertically downward from the upper surface of the drywell floor into the suppression chamber. The end of the vent pipes exhaust 8 ft below the suppression pool minimum water level. This method of steam condensing allows the primary containment to be designed to contain a

LOCA within a relatively small volume.

Vacuum Relief System

During a LOCA, steam condensation lowers drywell pressure below the suppression chamber pressure. A pair of vacuum breakers is installed in six of the interconnecting vents. They actuate to vent noncondensable gases from the suppression chamber to the drywell whenever suppression chamber pressure exceeds drywell pressure by 0.25 psid. This limits the upward force on the drywell floor to a maximum of 3 psid. The suppression chamber-to-drywell vacuum breakers are remotely tested using air cylinder actuators.

Drywell Air Cooling System

During normal plant operation there is a closed atmosphere within the drywell and suppression chamber. Since the reactor vessel is located within the drywell, heat must be continuously removed from the drywell atmosphere. Drywell average temperature is maintained less than 135°F by operating from one to eight drywell cooling units. Each cooling unit consists of a motor driven fan which forces the existing drywell atmosphere (either nitrogen gas or air) past a cooling coil heat exchanger which is cooled by the Reactor Building Closed Loop Cooling Water (RBCLCW) system. The drywell air cooling system isolates during accident conditions to prevent compromising primary containment integrity.

Limiting the maximum drywell atmospheric temperature ensures proper operation of:

- motors
- valves
- sensors
- instrument and electrical cables
- gasket materials or sealants

Primary Containment Purge System

The purpose of the primary containment purge system is to provide the means for supplying influent air to and for effluent atmosphere to be removed from the drywell and suppression chamber. The Reactor Building Normal Ventilation System (RBNVS) supplies filtered and tempered fresh air to the primary containment purge system for air purge and continuous ventilation which permits personnel access and occupancy during periods of reactor shutdown and refueling/maintenance operations. Normally, purge air is discharged at 10,000 scfm using the purge exhaust fan.

The drywell/suppression chamber purge or vent exhaust air is removed by the primary containment purge system and discharged to either the station ventilation exhaust stack via the RBNVS elevated release point atop the reactor building via the Reactor Building Standby Ventilation System (RBSVS).

When excess radiation is detected, purge exhaust is accomplished by directing 1,000 scfm air flow through a purge filter and purge filter exhaust fan. The purge filter consists of an initial HEPA filter, a charcoal filter, and a final HEPA filter that are designed to reduce contamination and radioactive iodine in the exhaust to acceptable levels prior to release. The purge exhaust filter and fan may also be used to vent excess pressure from the primary containment. Pressure may increase as heatup of the drywell atmosphere occurs during plant startup or by normal operation of pneumatically operated valves and/or minor instrument air/nitrogen leakage.

Containment Inerting System

The purpose of the containment inerting system is to create and maintain an inerted atmosphere of nitrogen gas inside the primary containment during normal power operation. Also, it supplies all inboard pneumatically operated equipment in the primary containment thus precluding the addition of any oxygen to the containment atmosphere through component operation or leakage. The inerting system is capable of reducing the oxygen concentration in the drywell and suppression chamber from a normal concentration of 21 percent to less than 4 percent (by volume) within 10 hours. An inerted atmosphere prevents an explosive mixture of hydrogen and oxygen from forming following a LOCA. Post LOCA hydrogen can be produced from radiolytic decomposition of water and/or the Zircaloy-water reaction listed below:

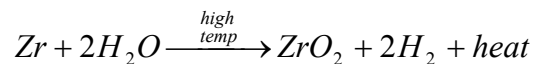

The containment inerting system consists of a nitrogen (N₂) purge supply and a N₂ makeup supply. The N₂ purge supply is a large capacity subsystem that is used to create the initial inerted atmosphere in the primary containment. It consists of:

- a 11,000 gallon liquid nitrogen storage tank,
- an electric vaporizer (to convert the liquid nitrogen to a gaseous state), and
- associated valves and piping to deliver nitrogen to the primary containment.

Nitrogen gas is added to the primary containment through the purge supply at a rate of 1000 scfm while simultaneously discharging primary containment atmosphere to either the RBNVS exhaust vent or to the RBSVS. The initial operation continues until the primary containment oxygen concentration is lowered to less than 4%.

Following the initial inerting of the containment subsequent N₂ additions are required. The nitrogen makeup supply will be required to compensate for temperature changes, leakage and lowering of the slight positive pressure in the primary containment. The makeup supply shares the liquid nitrogen storage tank, but has its own smaller capacity vaporizer to deliver nitrogen gas at a rate of 100 scfm.

Containment Combustible Gas Control System

The Containment Combustible Gas Control (CCGC) system is designed to monitor and control the concentration of combustible gases in the primary containment subsequent to a LOCA with postulated high hydrogen generation rates. It has the capability for: measuring the oxygen and hydrogen concentration in the primary containment mixing the atmospheres in the drywell and suppression chamber controlling gas concentrations to <5% by volume of oxygen without reliance on purging of the primary containment

Subsystems of the CCGC System include:

- primary containment hydrogen and oxygen analyzers
- containment atmosphere mixers
- hydrogen and oxygen recombiners
- N₂ dilution

Redundant hydrogen and oxygen sampling subsystems are available to measure the amounts of hydrogen and oxygen in the containment during normal or LOCA conditions. Representative samples are assured because of uniform mixing of the containment atmosphere by the:

- Drywell Air Cooling System during normal plant operations
- Containment Spray System during LOCA conditions.

A containment atmosphere mixing subsystem consists of the containment spray mode of the RHR System. It is initiated approximately 600 seconds after the occurrence of a postulated accident. Containment spray would be directed to the drywell and suppression chamber in an intermittent or continuous manner to induce turbulence to ensure a well mixed atmosphere. The spill-out of steam and water through the broken pipe also creates a large degree of turbulence that promotes mixing of the entrained hydrogen and oxygen. The natural convection currents arising as a result of temperature differences between the containment atmosphere and walls will also promote good mixing and prevent hydrogen and oxygen stratification.

The hydrogen and oxygen recombiner subsystem consists of two 100% capacity thermal recombiners that are designed to combine hydrogen with oxygen to maintain hydrogen concentration below 5% following a postulated LOCA. Water vapor formed as a result of the reaction is directed to the suppression chamber. The system flowrate is at least 60 scfm with an operating reaction chamber temperature of 1300°F. The recombiners are located in the reactor building. Following a LOCA the system is aligned to the primary containment and placed into service approximately 48 hours following the accident.

As a backup to the recombiners, a nitrogen dilution subsystem is available to control the concentration of combustible gases in the primary containment. The subsystem receives N₂ from the primary containment N₂ inerting system and then directs N₂ gas to

the containment. Nitrogen addition to the primary containment will increase containment pressure. If containment pressure approaches 24 psig a purge will be initiated to the reactor building using the containment purge filter system. Venting continues until containment pressure has been reduced to atmospheric.

Following a LOCA the nitrogen dilution system would be operated manually as necessary to keep the oxygen concentration <5% or the hydrogen concentration <4% in each volume.

6.2.3.2 Containment Response to a LOCA

The Design Basis Accident (DBA) LOCA is a complete circumferential break of a recirculation system 28 inch pump suction line. This accident results in worst case peak drywell pressure and temperature conditions. Table 4.1-3 illustrates the Primary Containment response to the DBA. Results are based on the assumption that the reactor and primary containment are at limiting operating conditions immediately preceding the accident. A brief explanation of the accident chronology is given in the following paragraphs.

t = 0 seconds

The postulated line break occurs and the drywell immediately pressurizes. A reactor scram is initiated by vessel low water level. An additional scram signal and containment isolation occurs when drywell pressure reaches 1.69 psig. The Main Steam Isolation Valves (MSIVs) receive closure signals from level 1 reactor vessel water level and main steam line high radiation and are expected to be fully closed 3.5 seconds later.

t = 0.53 seconds

The drywell pressurization is sufficient to cause the interconnecting vents to be cleared of water. The drywell nitrogen atmosphere and steam blow down through the vertical interconnecting vents and into the suppression pool. The steam condenses in the suppression pool which suppresses the drywell peak pressure. Drywell to suppression chamber differential pressure reaches a maximum value of 22.6 psid.

t = 9.26 seconds

Drywell pressure peaks at 46.0 psig (293.5°F saturation temperature), the time during which vessel blowdown changes from a liquid only to a two-phase mixture. This condition is assumed to occur when vessel level drops to the elevation of the recirculation suction line. noncondensable gases discharged into the suppression pool during the blowdown period end up in the free air volume of the suppression chamber which results in an increase of suppression chamber pressure to approximately 34 psig. As LOCA steam is condensed in the suppression pool, drywell pressure decreases and stabilizes about 38 psig and

suppression pool temperature reaches approximately 136°F.

t = 30.0 seconds

CS and LPCI begin pumping water into the reactor vessel. The injected water removes decay heat and stored heat from the core and transports that heat out of the reactor vessel in the form of hot water. The hot water leaves the reactor via the broken recirculation loop, collects on the drywell floor, and then flows into the suppression chamber via the downcomer pipes. Thus, a closed loop is formed with low pressure ECCS pumping water from the suppression pool to the reactor vessel, water returns to the suppression pool from the broken loop, and the process is repeated.

t = 57.7 seconds

Drywell pressure equals reactor pressure which terminates blowdown from the reactor. Shortly thereafter, drywell pressure has decreased to the point that suppression chamber pressure exceeds it by 0.25 psid. This causes the suppression chamber to drywell vacuum breakers to open and vent noncondensable gases into the drywell which equalizes the drywell and suppression chamber pressures.

t = 179.5 seconds

The reactor vessel is reflooded to the level of the recirculation loops. Water level inside the core shroud is expected to be at or above two-thirds ($\frac{2}{3}$) core height.

t = 600 seconds

It is assumed that the RHR System is realigned from the LPCI Mode to the containment spray mode. Suppression pool water is pumped by the RHR pump, through the RHR heat exchanger, and then delivered to the containment spray headers in the suppression chamber. Suppression pool heat is rejected to the RHR heat exchangers lowering primary containment temperature and pressure. The containment spray system delivers approximately five percent of its flow to the suppression chamber for cooling and steam condensation. If necessary to control primary containment pressure, the containment spray mode of the RHR System can be aligned to spray cooled suppression pool water into the drywell and/or suppression chamber atmospheres.

6.2.4 Mark III Containment

BWR/6 product lines use the Mark III containment concept. The Mark III containment is a multibarrier, pressure suppression style containment. The containment structure is similar to a standard dry containment and can be designed as either a free standing steel containment surrounded by a concrete shield building or as a concrete pressure vessel with a liner. The former design is referred to as the reference design while the latter is the

alternate. Discussion in this section is limited to the reference design.

The primary containment consists of several major components, many of which can be seen in figure 6.2-5. The drywell is a cylindrical, reinforced concrete structure with a removable steel head and encloses the reactor vessel. It is designed to withstand and confine the steam generated during a pipe rupture inside containment and channel this steam into the suppression pool via the weir wall and horizontal vents. The suppression pool contains a large volume of water to act as a heat sink and water source for ECCSs. A leak tight cylindrical steel containment vessel surrounds the drywell and the suppression pool to prevent gaseous and particulate fission products from escaping to the environment.

6.2.4.1 Component Description

The major components of the primary containment system are discussed in the paragraphs that follow.

Drywell

The drywell is a cylindrical reinforced concrete structure with a removable vessel head to allow vertical access to the reactor vessel for refueling or maintenance. The drywell is designed for an internal pressure of 30 psig, an external pressure of 21 psig, and an internal temperature of 330°F. However, a high degree of leak tightness is not a requirement since the drywell is not a fission product barrier.

Large diameter horizontal vent openings penetrate the lower section of the drywell cylindrical wall to channel steam from a LOCA into the suppression pool.

The main function of the drywell is to contain the steam released from a LOCA and direct it into the suppression pool. Other functions of the drywell include:

- provide shielding to reduce containment radiation levels to allow normal access.
- provide structural support for the upper pool.
- provide support structure for work platforms, monorails, and pipe supports.

Horizontal Vents and Weir Wall

The weir wall forms the inner boundary of the suppression pool, and is located inside the drywell. It is constructed of reinforced concrete approximately two feet thick and lined with a steel plate on the suppression pool side.

Since the weir wall forms the inside wall of the suppression pool, it contains the pool and allows channeling the steam released by a LOCA into the suppression pool for condensation. The weir wall height is 25 feet and allows a minimum freeboard of 5 feet 8 inches. This freeboard is sufficient height to prevent the suppression pool from

overflowing into the drywell.

The Mark III arrangement uses horizontal vents to conduct the steam from the drywell to the suppression pool following a LOCA. Figure 6.2-6 shows an enlarged horizontal and vertical section of vents. In the vertical section, the drywell wall is penetrated by a series of 27.5 inch diameter horizontal vent pipes. There are 3 rows of these horizontal pipes at levels of 7.5, 12 and 16.5 feet below the surface of the suppression pool. The total pool depth is approximately 20 feet. The horizontal section is a partial view of the 40 column of vents, vent annulus, and weir wall.

Any buildup of drywell pressure forces the water down in the annulus. The higher the pressure in the drywell, the greater the depression and the number of vents that will be uncovered.

Containment

The containment is a free standing cylindrical steel pressure vessel that surrounds the drywell and suppression pool to form the primary leak tight barrier to limit fission product leakage during a LOCA. By design the containment will not leak more than 0.1% of the containment volume in 24 hours at a pressure of 15 psig.

Among the postulated LOCAs, some accidents may require flooding the containment to remove fuel from the reactor and effect repairs. Although it is anticipated that for most accidents, defueling of the reactor will be accomplished by normal procedures and equipment, as a contingency to cover undefined damage resulting from a LOCA, the containment can be flooded to a level 6 feet 10 inches above the top of the active fuel in the core.

Upper Pool

The containment upper pool walls are above the drywell and within the containment column. The pool is completely lined with stainless steel plates and consists of five regions:

- moisture separator storage
- reactor well
- steam dryer storage
- temporary fuel storage
- fuel transfer region

The upper pool provides radiation shielding when the reactor is operating, storage for refueling operation, and a source of water makeup for the suppression pool following a LOCA.

Combustible Gas Control

To ensure containment integrity is not endangered because of the generation of combustible gases following a postulated LOCA, the containment is protected by a collection of systems called the containment combustible gas control system (CCGC system).

The CCGC system, figure 6.2-7, prevents hydrogen concentration in the primary containment from exceeding the flammability limit of 4% (by volume). The system is capable of mixing the atmosphere inside the drywell with that inside containment following a LOCA. When the drywell hydrogen concentration begins to increase, the drywell mixing compressors are started manually by the control room operator. Air from the containment is pumped into the drywell increasing drywell pressure. The increase in drywell pressure depresses the annulus water uncovering vents and allowing the drywell atmosphere to mix with the containment.

While drywell mixing continues following a LOCA, hydrogen continues to be produced. Eventually, the 4% limit is approached in the containment, requiring the hydrogen recombiners and hydrogen ignition system to be manually placed in operation. The recombiners are located in the containment upper region. Air flow through the recombiner is designed to process 100 cfm of containment air, heating it to 1150°F. The heated air leaving the heater section is mixed with containment atmosphere to limit the outlet temperature to approximately 50°F above ambient.

The hydrogen ignition system consists of hydrogen ignitors distributed throughout the drywell and containment. The ignitors burn the hydrogen as its evolved to maintain the concentration below detonable limits.

A small line, connecting the drywell with the shield building annulus, is used during reactor startup and heatup. Drywell pressure is vented to the annulus through the bleedoff and backup purge line. This venting can support plant heatup at the design rate of 100 °F/hr. If hydrogen recombiners are not available subsequent to a LOCA, the drywell bleedoff valves may be opened for backup purging. This flowpath allows about 100 cfm of air from the drywell to enter the shield building annulus where it is removed and then later processed by the standby gas treatment system.

6.2.4.2 Containment Response to a LOCA

Following a design basis LOCA, the high energy of the break flow rapidly raises drywell pressure and temperature. The rise in drywell pressure causes the water level in the vent annulus area of the weir wall to drop uncovering the horizontal vents. Once water level drops to the tops of the vents, the drywell is vented into the suppression pool where the energy from the blowdown is absorbed and suppressed in the suppression pool.

The higher the water level in the vent annulus, the longer it takes to start to relieve pressure.

If drywell pressure is less than the primary containment airspace pressure, the water level in the weir annulus will increase and, consequently, the liquid inertia above the top vent will increase. This will cause top vent clearing during a postulated LOCA to be delayed, and that would increase the peak drywell pressure.

During the blowdown period of the LOCA, the pressure suppression vent system conducts the flow of the steam-water gas mixture in the drywell to the suppression pool for condensation of the steam. The pressure differential between the drywell and suppression pool controls this flow.

Following vent clearing, the drywell pressure decreases as the break flow decreases.

At the end of the blowdown, the drywell pressure stabilizes at a slightly higher pressure than the containment, the difference being equal to the hydrostatic head of vent submergence. The drywell will contain saturated steam.

The containment is pressurized early in the transient by the carryover of noncondensibles from the drywell. As the transient continues, break flow is injected into the suppression pool, and the temperature of the suppression pool water increases, causing the containment pressure to increase.

The maximum drywell pressure occurs during the blowdown phase of a main steam line break. Drywell pressure also peaks for a recirculation line break during the blowdown phase.

The peak containment pressure occurs during the long-term phase of the transient when the peak suppression pool temperature is reached. The most severe drywell temperature condition (peak temperature and duration) occurs for a small primary system rupture above the reactor water level that results in the blowdown of reactor steam to the drywell (small steam break).

Containment design is limited by the long-term pressure response driven by the suppression pool temperature where the assumption of thermal equilibrium between the suppression pool and containment is conservative.

For a **recirculation line break**, the RPV is flooded to the height of the jet pump nozzles, the excess flow discharges through the recirculation line break into the drywell. This flow of water (steam flow is negligible) transports the core decay heat out of the RPV, through the broken recirculation line, in the form of hot water which flows into the suppression pool via the drywell-to-suppression pool vent system.

For a **main steam line break**, initial vessel depressurization of the reactor vessel is very rapid and results in the maximum drywell differential pressure. During the first second of the blowdown, the blowdown flow will consist of saturated steam. This steam will enter the drywell in a superheated condition of approximately 330°F. Void formation in the reactor vessel water causes a rapid rise in the water level. From that time on, break flow is a two-phase mixture.

As reactor pressure drops, ECCS flow starts. Eventually ECCS flow will spill into the drywell. The water spillage will condense the steam in the drywell and thus reduce the drywell pressure. As soon as the drywell pressure drops below the containment pressure, the drywell vacuum breakers will open and noncondensable gases from the containment will flow back into the drywell.

Vacuum breaker action eliminates Suppression Pool back-flood.

No single accident results in exceeding the design parameters of the Drywell or Containment.

6.2.5 Refueling

6.2.5.1 Mark I and II

Vessel Servicing Subsystem

The Vessel Servicing Subsystem provides the equipment necessary to remove, store, inspect, and install various reactor vessel components. The reactor vessel is serviced from both the refueling floor and the under vessel area.

There are three floodable volumes on the refueling floor (see figure 6.2-8); the spent fuel pool, the reactor cavity and the dryer/separator storage pool. Dry laydown areas are provided on the refuel floor for the following

- the drywell head
- the vessel head
- the vessel head insulation.

The reactor building overhead crane is a bridge type crane spanning the interior of the reactor building. Its services include handling the drywell head, vessel head, steam dryer, and steam separator during refueling. Typically the crane has a 125 ton capacity with a 35 ton auxiliary hoist.

In order to perform the required reactor servicing, the reactor is shut down according to prescribed procedures. During the cooldown the reactor pressure vessel is vented and filled to above the flange level to promote cooling. The shield blocks are removed from above the drywell head region after the reactor is shutdown.

Immediately after vessel cooldown the drywell head is removed. The unbolted drywell head is lifted by the reactor building overhead crane to its refuel floor storage space.

All interfering piping, instrumentation, and vessel head insulation are removed from the reactor vessel head. The vessel head strongback and carousel is then positioned on the reactor vessel head by the overhead crane. The strongback attaches to the vessel head at four points via lifting eyes on the vessel head. The four connecting points have a leveling

adjustment to ensure the head is level prior to lifting.

The head stud tensioners are used to remove and reassemble the reactor vessel head retaining nuts. The assembly includes eight stud tensioners in a carousel suspended from the head strongback. The carousel structure has a circular, rail mounted, 1 ton, power hoist for each tensioner. This permits working on eight studs at each operation.

After the retaining nuts are removed, the vessel head is lifted to its storage location on the refueling floor. The six vessel studs in line with the fuel transfer gate through the reactor cavity wall are removed from the vessel. These studs are removed to provide a path for fuel movement from the reactor cavity to the spent fuel pool.

Access to the fuel assemblies requires the removal of the steam dryer and separator. The steam dryer is removed using the dryer separator strongback and stored in the dryer/separator pool. The shroud head steam separator assembly can now be removed after the shroud head bolts are loosened using the shroud head bolt wrench. The shroud head separator assembly is removed using the dryer and separator strongback. This is then stored in the dryer/separator pool. Since the shroud head is expected to be highly radioactive, the separator assembly is usually transferred under water. Once access to the fuel is possible; the refueling platform is moved into place to commence fuel movement.

The reactor vessel service platform is a motor driven structural steel assembly designed to provide close access to the vessel internals. The platform rides on self contained rails which traverse the dryer/separator pool, the reactor cavity and the spent fuel pool. It has three hoists: the main hoist, and auxiliary hoist and a monorail hoist. The main hoist is used for refueling operations and has an attached telescopic mast. The platform and hoist are positioned by use of a bridge (forward and reverse) and trolley (left and right) motors. The main hoist controls both the fuel grapple and a mast that houses the fuel once removed from its core or storage location. The vessel internals are serviced with the aid of assorted long handled tools and accessories.

The primary function of the under reactor vessel servicing equipment is to remove and install control rod drives, control rod guide tubes, and neutron detectors.

The equipment handling platform is located below the reactor pressure vessel. The platform is capable of rotating forward and reverse for 360 degrees with access to the following:

- control rod drives
- source range monitor (SRM) drives
- intermediate range monitor (IRM) drives
- electrical connections for the incore detector assemblies (SRM, IRM and LPRM)
- transverse incore probe (TIP) tubing and connectors.

The control rod drive handling equipment is pneumatically powered and designed to remove and install the control rod drives. This equipment is used in conjunction with the equipment

handling platform.

Fuel Movement

To move fuel, the fuel grapple is aligned over a fuel assembly in the reactor. The mast is then lowered to just above the fuel and the grapple is lowered and attached to the fuel bundle bail handle. The fuel bundle is then raised out of the core and into the mast. The mast and fuel are then raised to provide clearance to the other fuel bundles and vessel components. The trolley and bridge are lined up to move through the gate in the reactor cavity wall to the spent fuel storage pool. In the spent fuel pool, the bridge and trolley are aligned over a position in the storage rack. The fuel bundle and mast are then lowered to just above the fuel rack. The fuel is then lowered into the storage location and the grapple is released from the fuel bundle bail handle. The new fuel is then moved from the spent fuel pool storage pool to the reactor vessel in the same manner. Some fuel moves are required from one vessel location to another in order to align fuel per the cycle design. These fuel moves will take a bundle from one in-core location and place it in another in-core location. The same process is followed for these in-core movements, but the fuel is lowered into a new core location instead of the spent fuel pool location. This is commonly called a fuel “shuffle”.

Spent fuel can be removed from the spent fuel pool and transferred off site or to on site dry fuel storage installation. A special shipping cask and/or transfer cask is needed for these evolutions.

6.2.5.2 Mark III

Vessel Servicing Subsystem

As with the Mark I and II containments, there are floodable volumes on the containment upper elevation (see figure 6.2-9); the reactor cavity, separator storage pool and dryer storage pool which includes the upper fuel transfer pool. Dry laydown areas are provided on the refuel floor for the following

- the drywell head
- the vessel head
- the vessel head insulation.

The reactor building overhead crane is a polar crane which rotates and trolleys to be able to access the entire interior of the containment building. Its services include handling the drywell head, vessel head, steam dryer, and steam separator during refueling.

The refueling platform and the fuel handling platform are movable, bridge-type structures which ride on rails above their working areas. The refueling platform travels over the reactor cavity and the various storage pools in the reactor building. It has 3 hoists: A main fuel hoist used with the telescoping fuel grapple, an auxiliary hoist, and a monorail mounted hoist.

The fuel handling platform travels over the fuel storage pools, transfer tube pool, and new fuel vaults in the Fuel Handling Building. It has two hoists: A main fuel hoist used with the telescoping fuel grapple and a monorail hoist.

The 360 degree auxiliary platform is a low silhouette platform which rides on rails inside of the refueling platform. It is capable of traversing the entire upper pool length. A section of the auxiliary platform can be installed to allow workers to work below upper pool level in a basket arrangement.

The major difference between the earlier BWR refueling designs and that of the BWR 6 is that the spent fuel pool is located in the fuel building at a much lower elevation and an Inclined fuel transfer system (IFTS) is used to transfer the fuel from the containment building to the fuel building. Refer to Figures 6.2-10 and 11.

The IFTS consists of a carriage that rides on tracks and is equipped with a tilt tube to support 2 fuel assemblies as they are moved. The carriage passes through an inclined transfer tube that provides a conduit between the containment building and the fuel building. Upending mechanisms located in both buildings raise the tilt tube to the vertical position. This allows the fuel assemblies to be inserted or removed.

Since the water level in the containment building is higher than that in the fuel building, a system of valves is employed to prevent an uncontrolled release of containment side water into the fuel building pool. This also ensures that the carriage and its cargo of fuel are sufficiently submerged at all times.

The carriage is driven by a winch and pulley system that can be operated from either side. The winch is located on the containment side. The associated components include a motor drive, two brakes, a load cell monitoring cable load, and dual position encoders used to monitor cable displacement indicative of the position of the carriage.

At each end of the transfer tube there is a hydraulically operated upender that allows the tilt tube (mounted to the carriage) to be rotated to the proper orientation for refuel operations. Control of each upender is from an operator panel located near the edge of the respective pool. Along with the operator panels there is a hydraulic power unit in close proximity that provides the motive forces required to upend the tilt tube and operate the valves.

Components of the upender include proximity type limit switches for monitoring upender position and cylinders for moving the upender up and down (inclined to vertical). Operator interaction with the machine is accomplished through several different components.

There are four operator panels that share the control of this system. Manual operation of individual components and automatic transfers are controlled by the following panels

- Containment building panel. The operation of the containment upender is only operated from this panel.

- Fuel building panel. The operation of the fuel handling building upender is only operated from this panel.

Touch screen indications and automatic transfers are also controlled by the following two panels.

- Remote touch screens located on the Refuel Platform.
- Remote touch screens located on Fuel Handling Platform.

Display of machine interlock conditions is accomplished with the use of indicator lights and a touch screen at each operator panel. The interlocking and control of the IFTS system along with its associated hardware is controlled by programmable logic controllers.

Fuel Movement

Refer to Figure Fig 6.2-11 during the following discussion.

The IFTS can transfer a component in either an automatic or a manual mode of operation. To gain a better understanding of the IFTS, the general sequence of events that occur during a transfer is presented below.

Assume that the system is powered up and the carriage is in the upper pool with the reactor building upender vertical and the flap valve open. The fill valve, drain valve, and bottom valve are closed, and the fuel handling building upender is inclined.

- Two fuel bundles are placed in the tilt tube and the refueling bridge grapple is clear of the upender.
- The reactor building operator initiates an AUTO RUN START.
- The upender automatically repositions to the INCLINED position.
- The winch initially lowers the carriage in slow speed, and then shifts to fast until it reaches the FILL/DRAIN position (below the level in the spent fuel pool) and stops.
- The Flap Valve then closes and the drain valve opens to drain the transfer tube down to the level of the lower pool. The water that is drained is routed to the fuel transfer drain tank in the fuel pool cooling and cleanup system.
- The bottom valve opens and the carriage is again initially lowered in slow, then shifts to fast speed and continue to lower until it reaches the fuel building SLOW zone. The winch then lowers in slow speed until slack cable is detected, at which point the winch continues to lower for an additional 3 seconds, to ensure that the cable is slack enough to allow the upender to be raised to vertical.
- The upender automatically moves to the VERTICAL position.

After the fuel handling bridge operator exchanges fuel bundles:

- The fuel building operator initiates an AUTO RUN START.

- The upender automatically repositions to INCLINED. The winch pulls up the slack cable, then raises the carriage initially in slow speed, then shifts to fast and stops at the FILL/DRAIN position.
- The bottom valve and drain valve close.
- The fill valve opens and the tube fills with water from the upper pool.
- When the tube is filled, the flap valve opens, the fill valve closes and the winch raises the carriage in fast speed. It shifts to slow when at the containment building SLOW zone.
- The upender automatically rises to the VERTICAL position.
- The refueling bridge operator can now exchange the fuel bundles and the cycle can be repeated as necessary.

6.2.6 Summary

The primary containment package provided for a particular product line is dependent on the vintage of the plant and the cost-benefit analysis at the time. During the evolution of the boiling water reactor, three major types of containments were built. The major containment designs are the Mark I, Mark II, and Mark III. Unlike the Mark III, that consists of a primary containment and a drywell, the Mark I and Mark II designs consist of a drywell and wetwell (suppression chamber). All three primary containment designs use the principle of pressure suppression for loss of coolant accidents. For comparison of containments see table 6.2-1.

Table 6.2-1 Containment Comparison Chart

	Mark I (BFNP)	Mark II (LaSalle)	Mark III (Perry)
Drywell Material	Steel	Concrete	Concrete
Drywell Thickness (ft)	.17	6	6
Drywell Upper Diameter (ft)	39	31	73
Drywell Lower Diameter (ft)	67	73	73
Drywell Height (ft)	115	91	89
Drywell Free Air Volume (ft ³)	159,000	209,300	277,685
Drywell Design Internal Pressure (psia)	56	45	30
Drywell Design External Pressure (psia)	2	5	21
Drywell Deck Design d/p (psid)	N/A	25	N/A
Drywell Design Temperature (°F)	281	340	330
Drywell max. Calculated LOCA Pressure (psia)	49.6	34	22.1
Shield above RPV Head	Concrete	Concrete	Water
Suppression Chamber (or Containment) Thickness (ft)	.17	4	.15
Suppression Chamber (or Containment) Steel Liner Thickness	N/A	.25	N/A
Suppression Chamber (or Containment) Diameter ft)	111	87	120
Suppression Chamber (or Containment) Height (ft)	31	67	183
Suppression Chamber (or Containment) Free Air Volume (ft ³)	119,000	164,500	1,141,014
Suppression Pool Volume in Drywell (ft ³)	N/A	N/A	11,215
Total Suppression Pool Volume (ft ³)	135,000	124,000	129,550
Upper Pool Makeup to Suppression Pool (ft ³)	N/A	N/A	32,830
Suppression Chamber (or Containment) Design Internal Pressure (psig)	56	45	15
Suppression Chamber (or Containment) Design External Pressure (psig)	2	5	0.8
Suppression Chamber (or Containment) Design Temperature	281	275	185
Suppression Chamber (or Containment) max. Calculated	27	28	11.31
Suppression Chamber (or Containment) design Leak Rate (% of vol/Day)	.5	.5	.2
Number of Drywell to Suppression Chamber (or Containment) vents	8	98	120
Total Vent Area (ft ²)	286	308	512
Drywell Atmosphere	N ₂	N ₂	Air

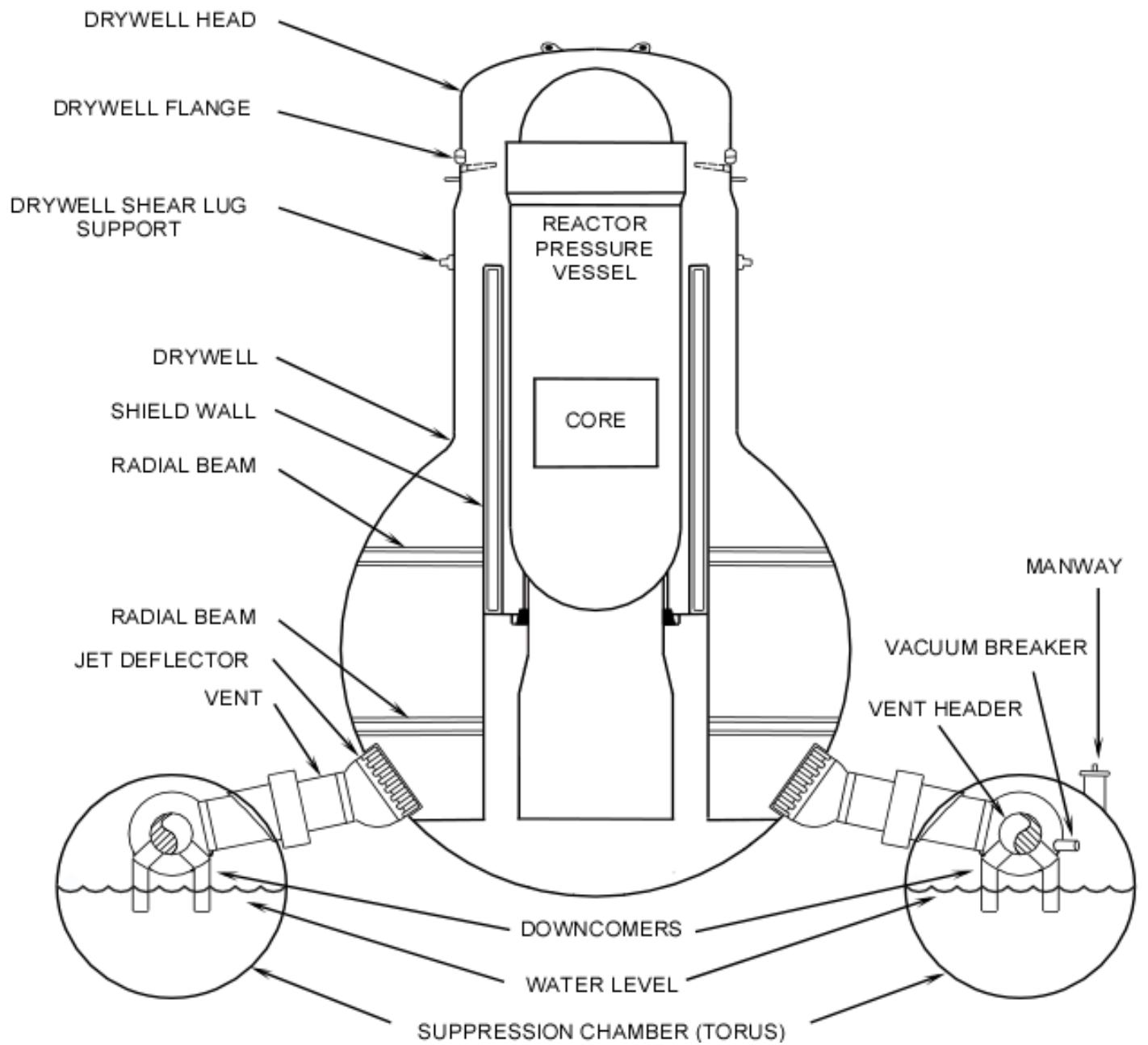

Figure 6.2-1 Mark I Containment

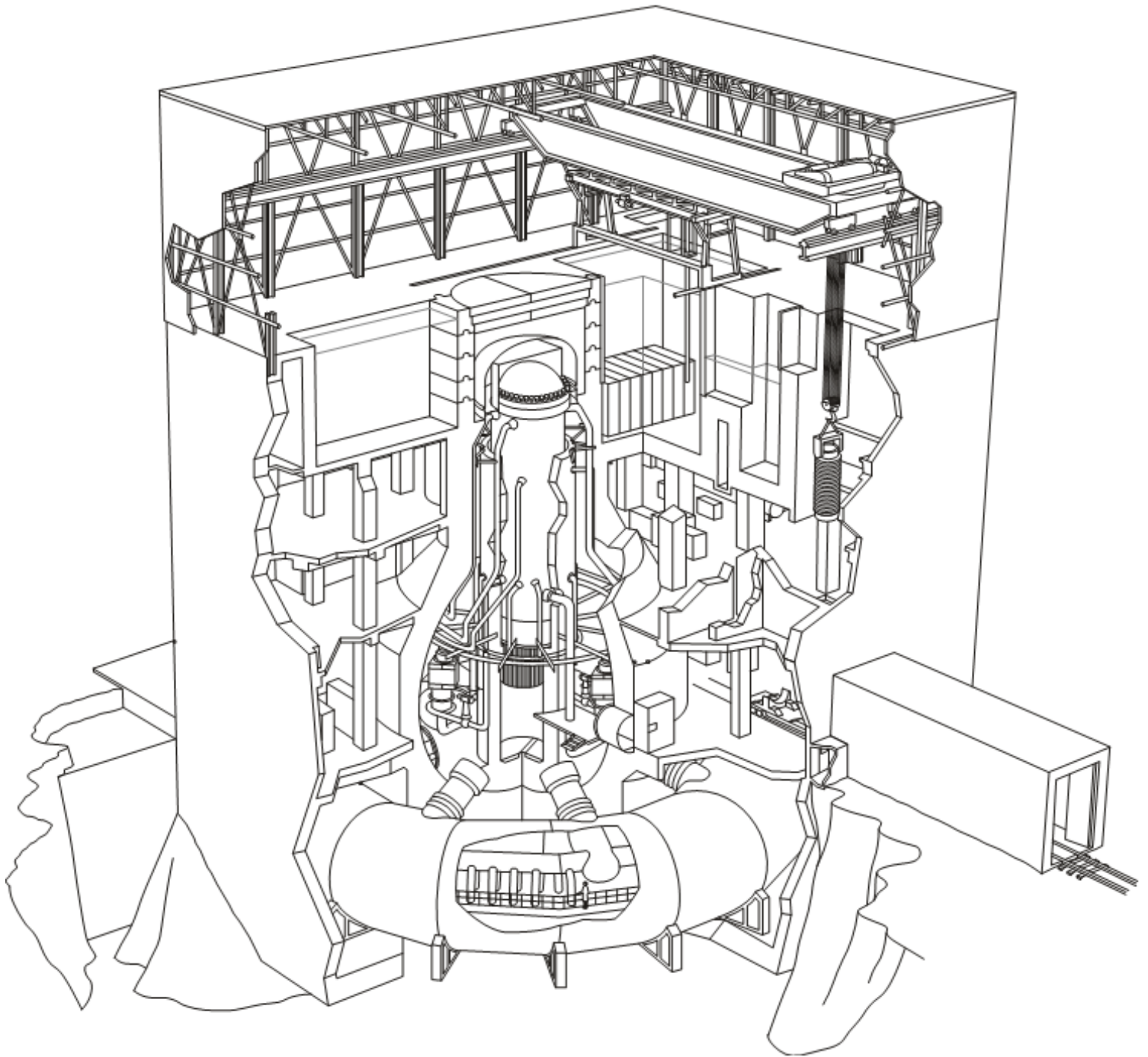

Figure 6.2-1a Mark I Reactor Building

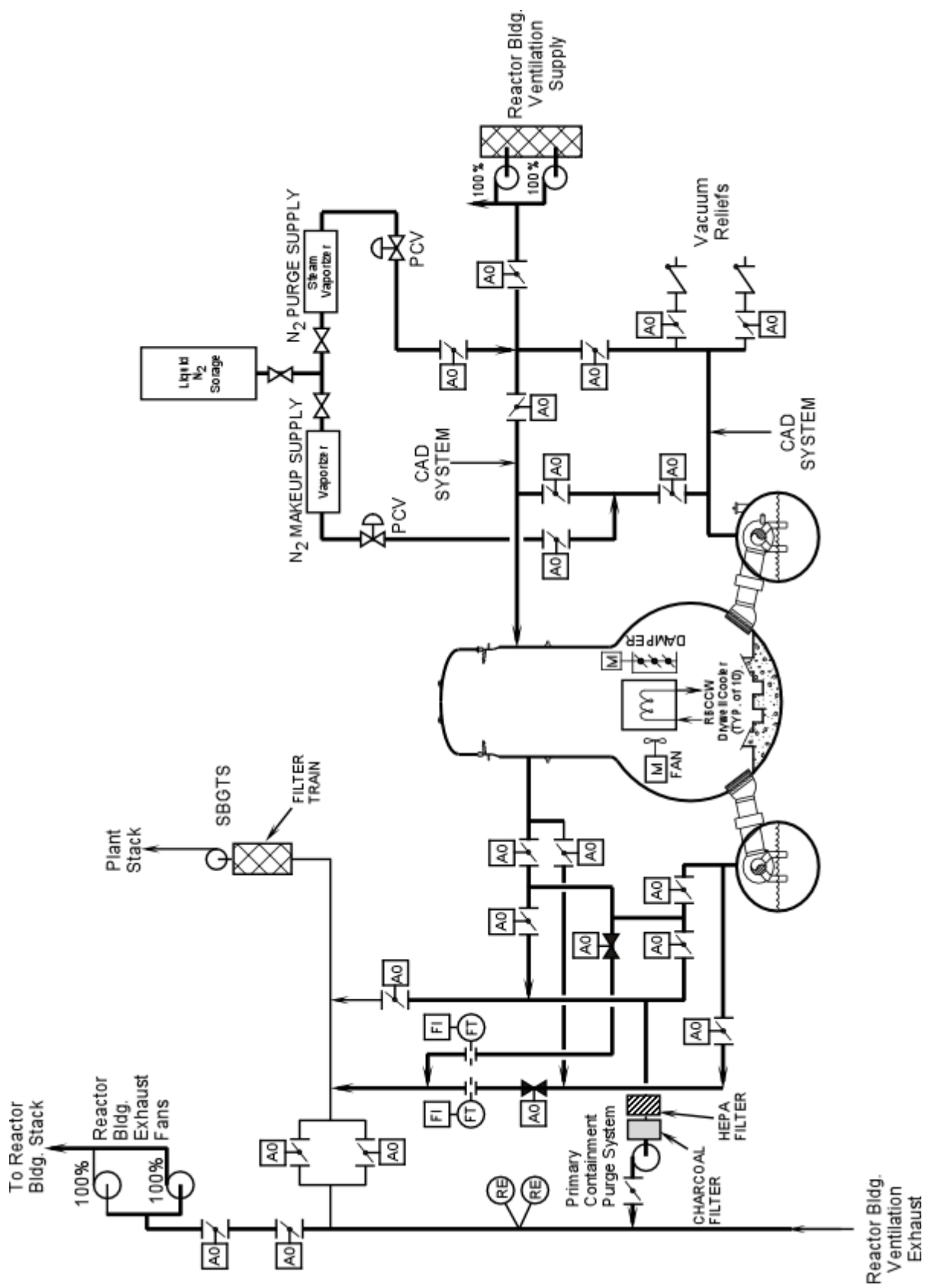

Figure 6.2-2 Mark I Containment Combustible Gas Control

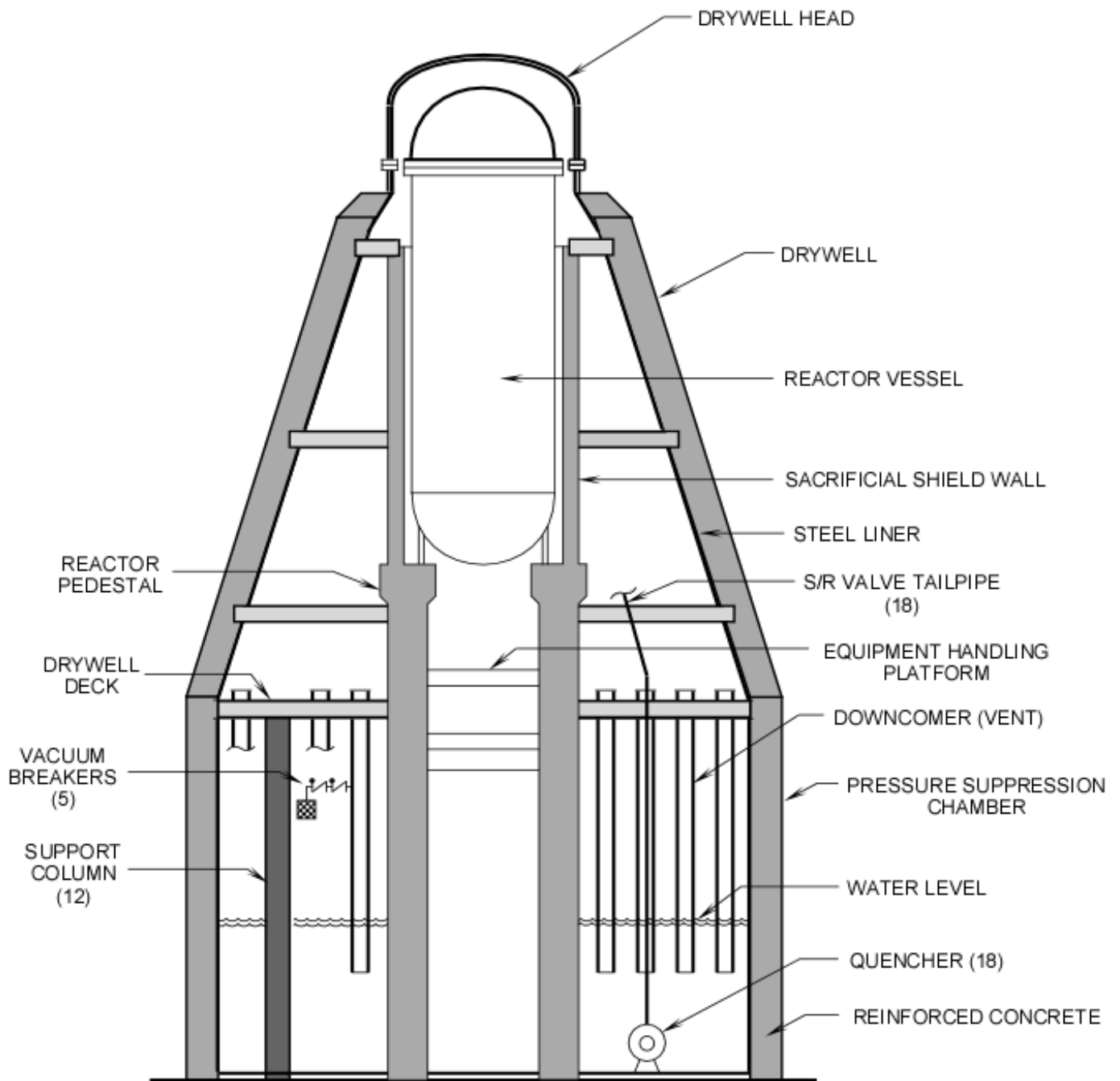

Figure 6.2-3 Mark II Containment

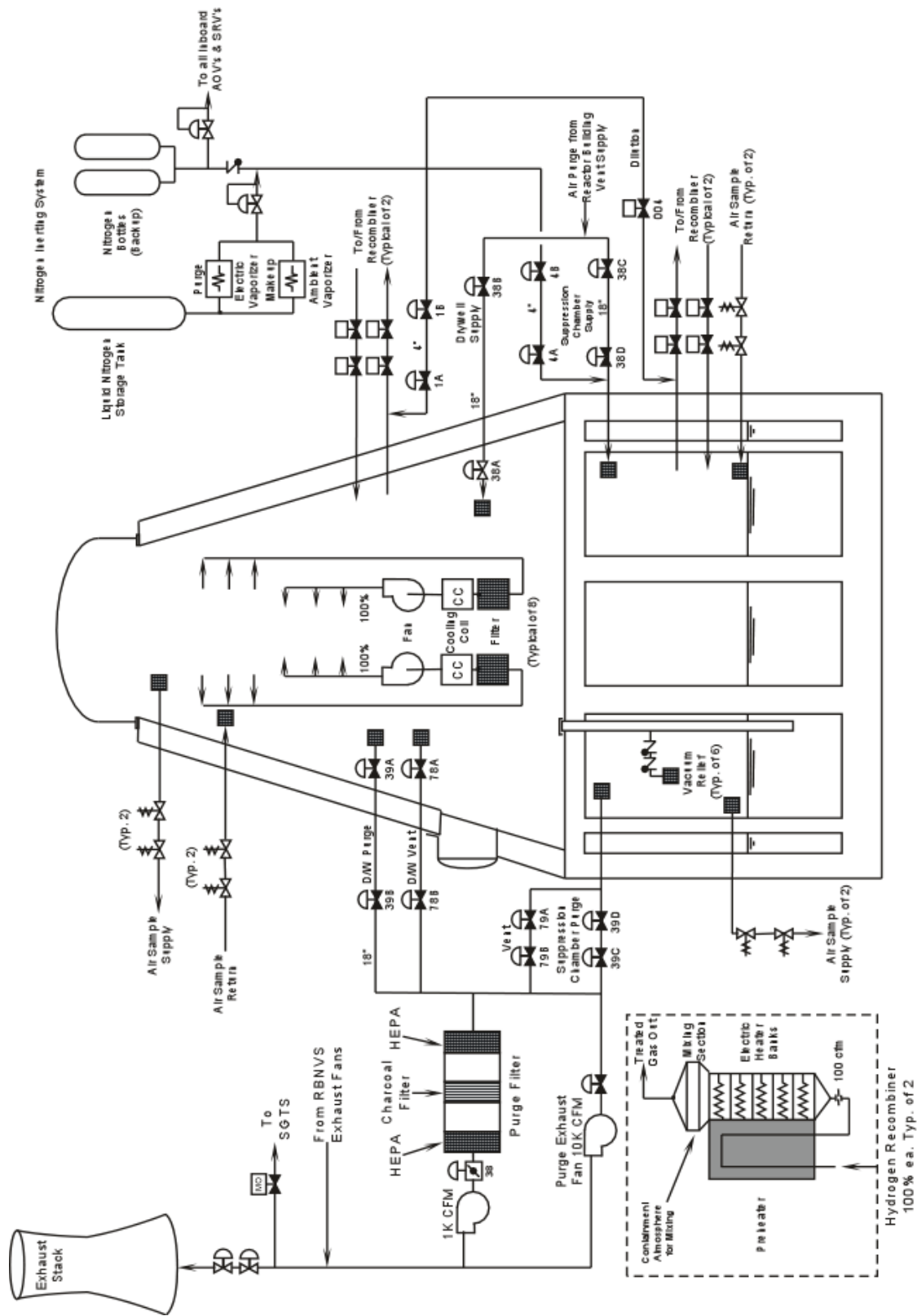

Figure 6.2-4 MARK II Containment Combustible Gas Control

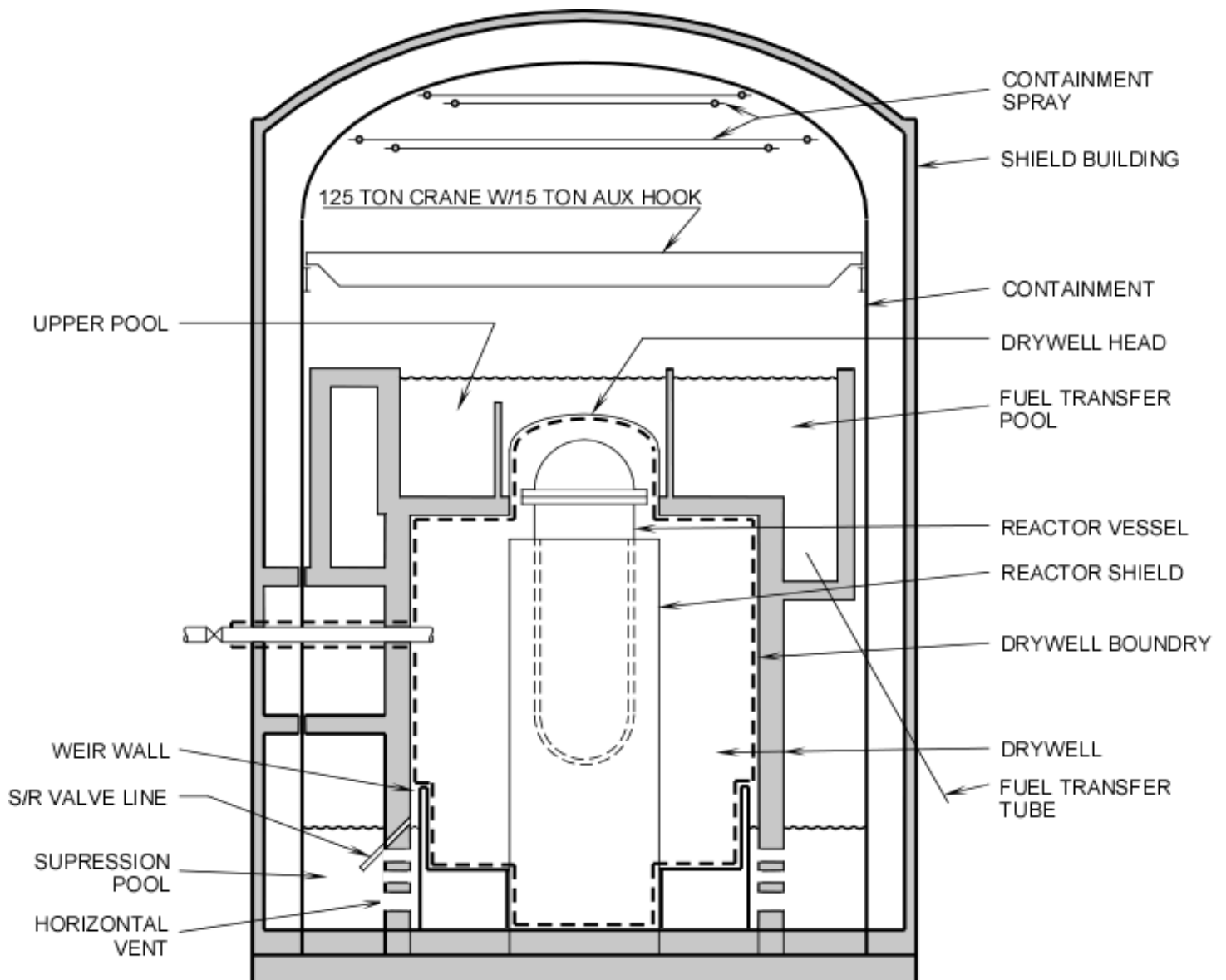

Figure 6.2-5 Mark III Containment

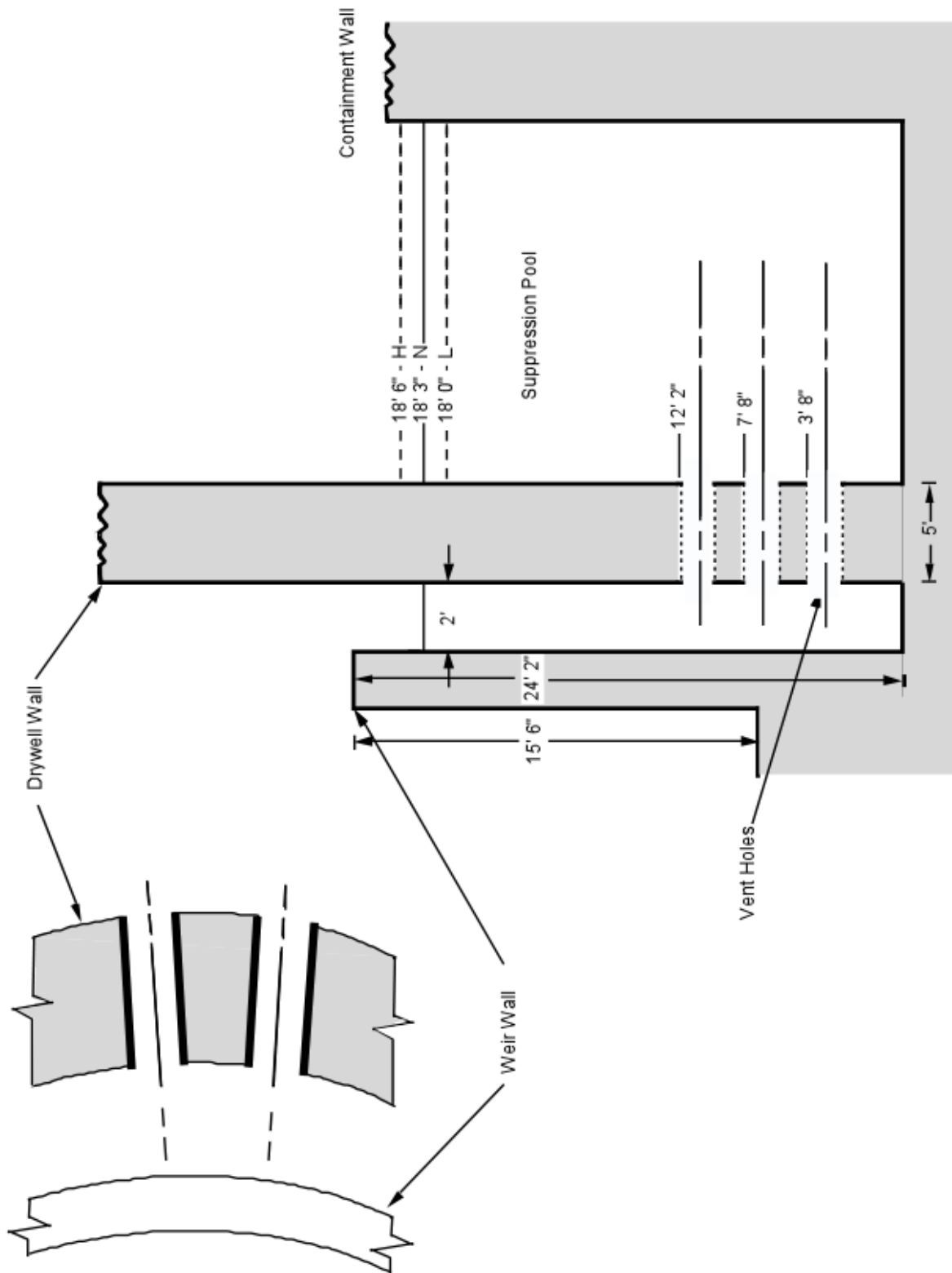

Figure 6.2-6 Mark III Containment Vent Arrangement

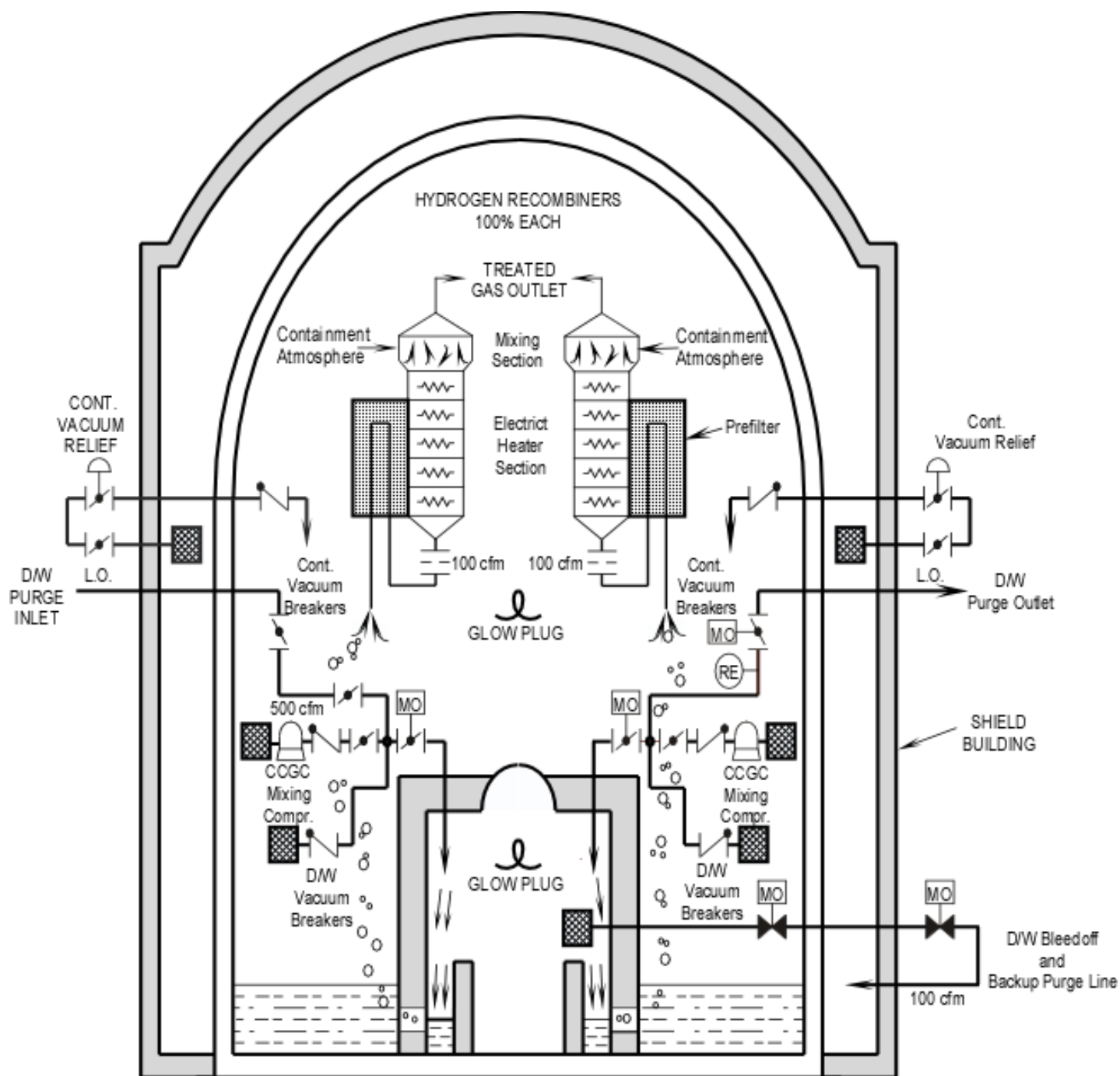

Figure 6.2-7 Mark III Containment Combustible Gas Control

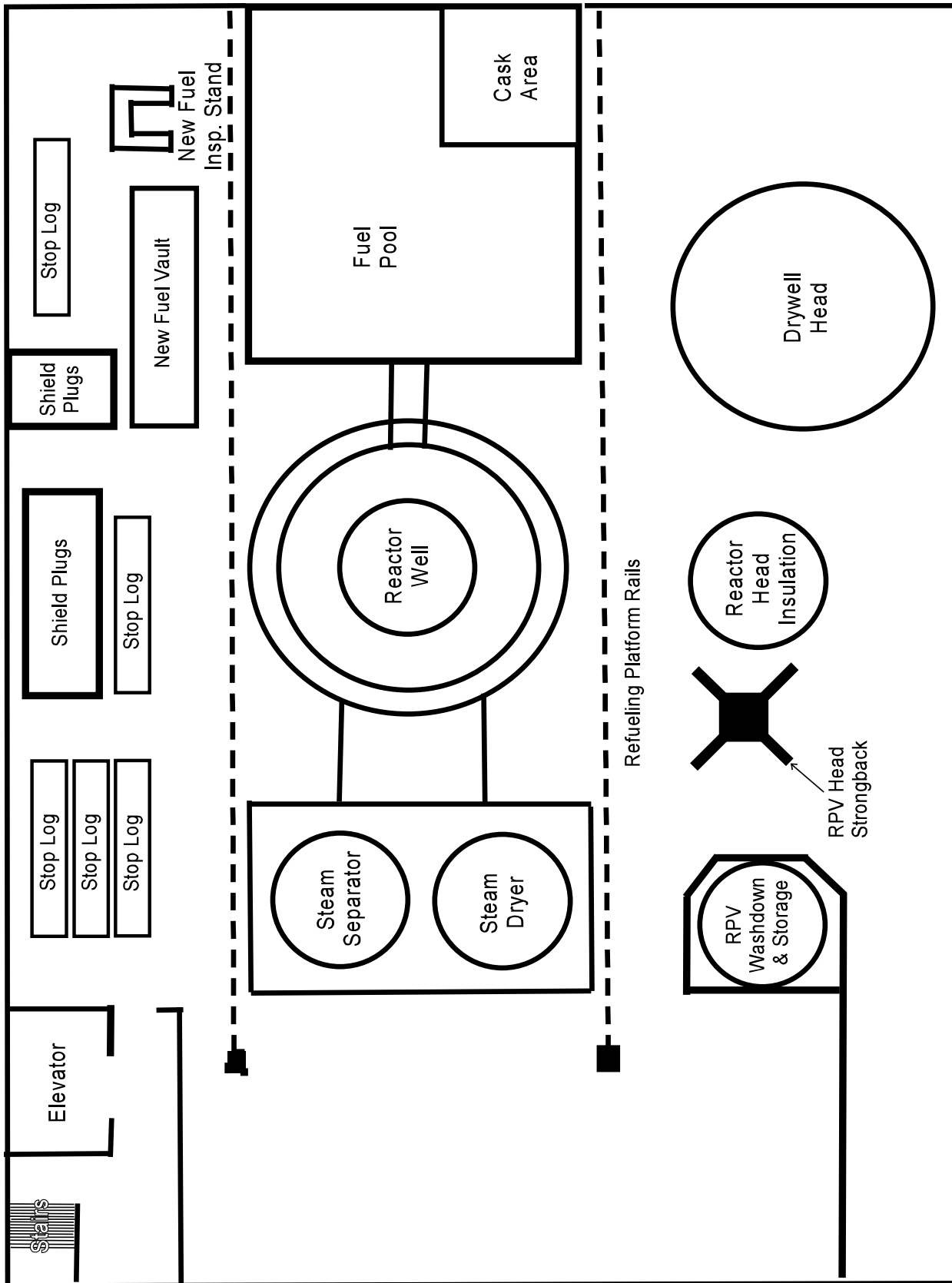

Figure 6.2-8 Mark I and II Refuel Floor

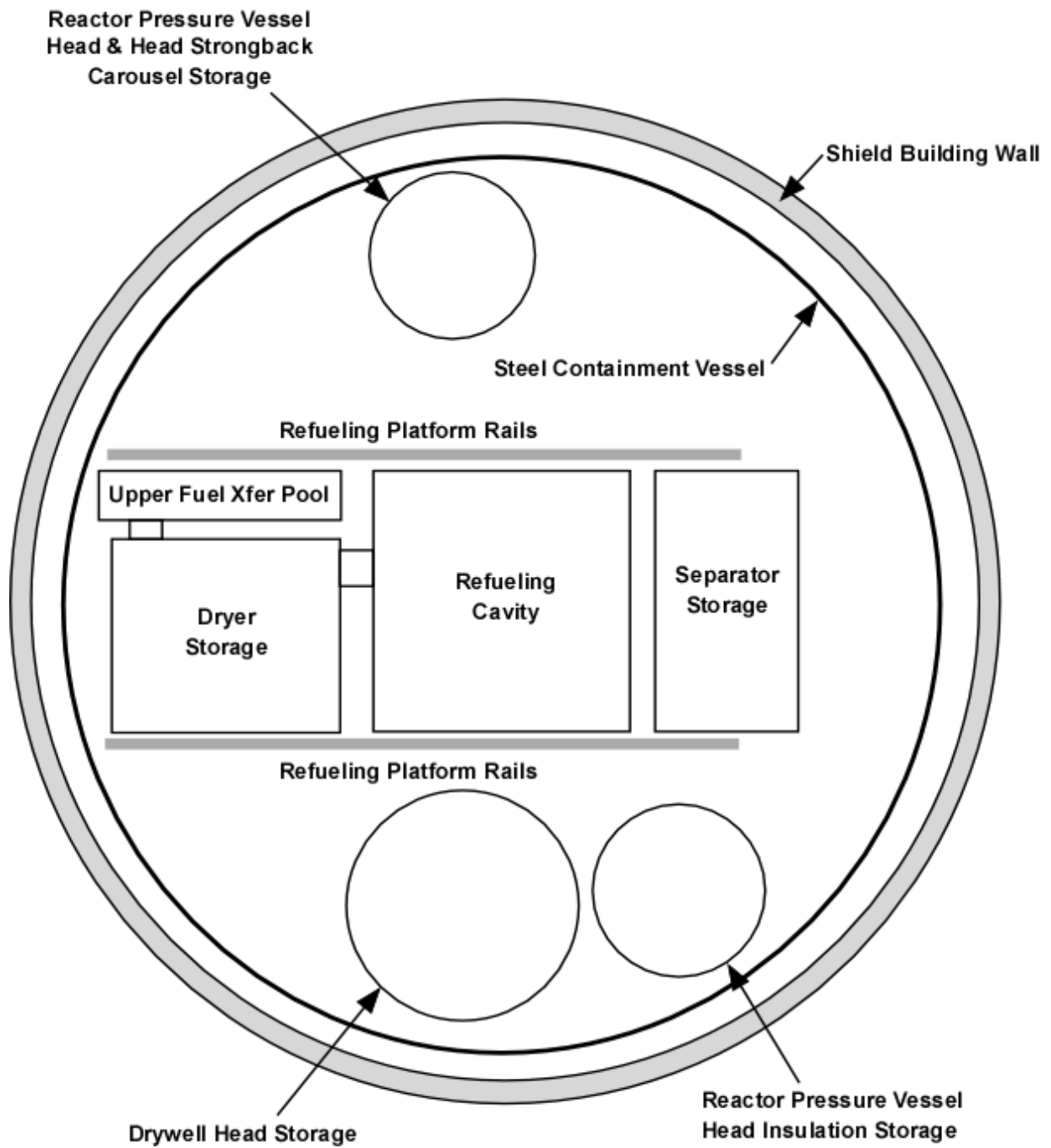

Figure 6.2-9 Mark III Refuel Floor

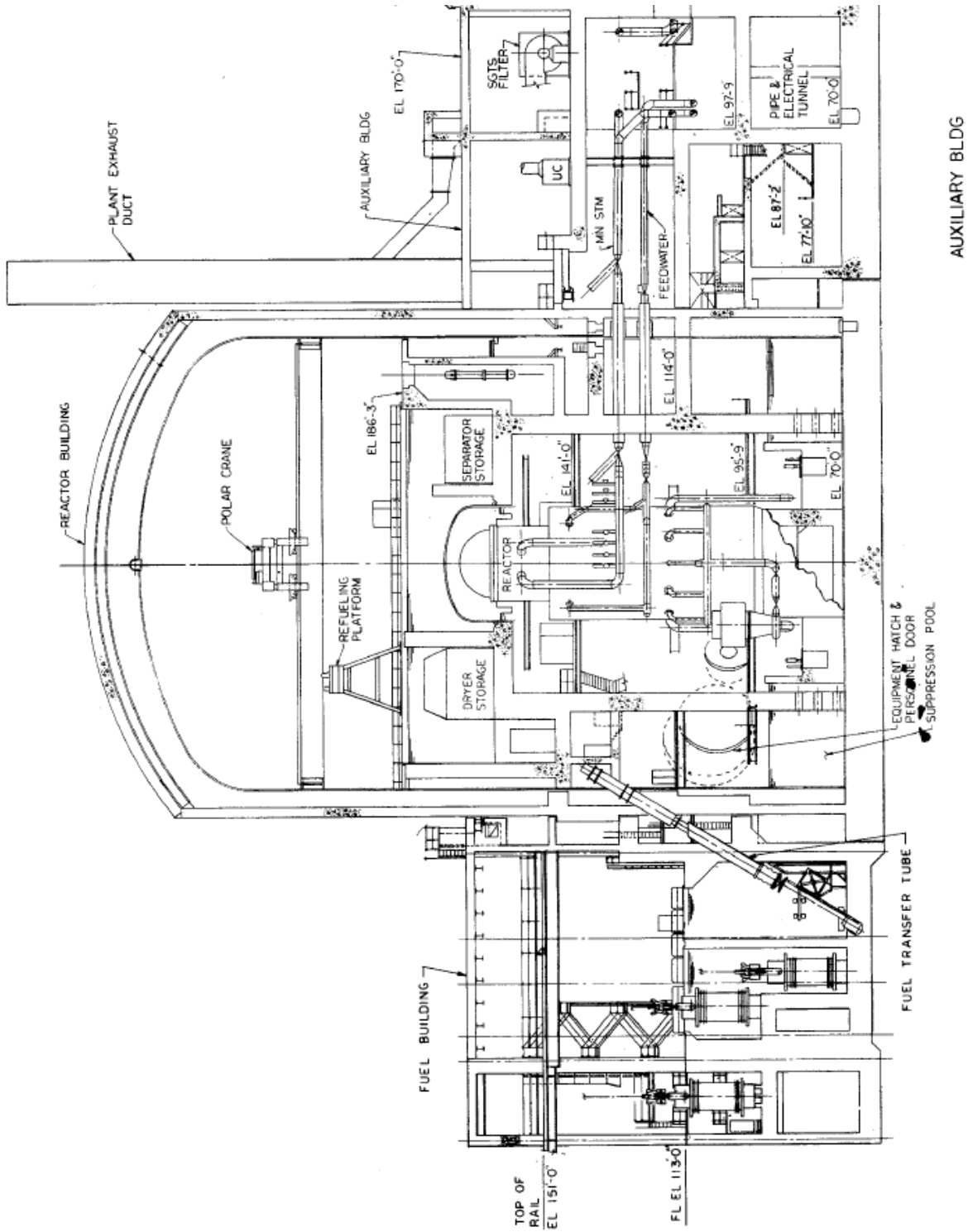

Figure 6.2-10 Mark III Reactor Building and Fuel Building Elevation Drawing

- A REACTOR BUILDING TRANSFER POOL
- B ISOLATION VALVE ROOM
- C FUEL BUILDING TRANSFER POOL
- 1 SHIELD BUILDING
- 2 STEEL CONTAINMENT
- 3 CABLE WINCH
- 4 ROLLER TRACK AND SUPPORT STRUCTURE
- 5 RAM ACTUATOR CYLINDER (SWIVEL MOUNTED)
- 6 FLAPPER VALVE
- 7 SHEAVE BOX
- 8 WATER INLET VALVE
- 9 ISOLATION VALVE
- 10 ADAPTOR
- 11 BELLOWS (TYPICAL FOR 32 in. I.D. PIPE)
- 12 GUARD TUBE (32 in. I.D. TYPICAL)
- 13 TRANSFER TUBE SUPPORT BOX
- 14 WATER EXIT VALVE
- 15 RADIATION SHIELDING
- 16 FUEL BUILDING WALL
- 17 REFUELING FLOOR LEVEL
- 18 VALVE
- 19 LIFT CABLE (TYPICAL OF 2)
- 20 TILTING TUBE (CONTAINING 2 FUEL BUNDLES)
- 21 RAM LATCHING MECHANISM
- 22 CARRIAGE (WITH ROLLERS AND CABLE ATTACHMENT)
- 23 PIVOT POINT
- 24 ACCOMMODATION PIT
- 25 ROLLER TRACK AND SUPPORT STRUCTURE
- 26 RAM ACTUATOR CYLINDER (SWIVEL MOUNTED)
- 27 GROUND LEVEL

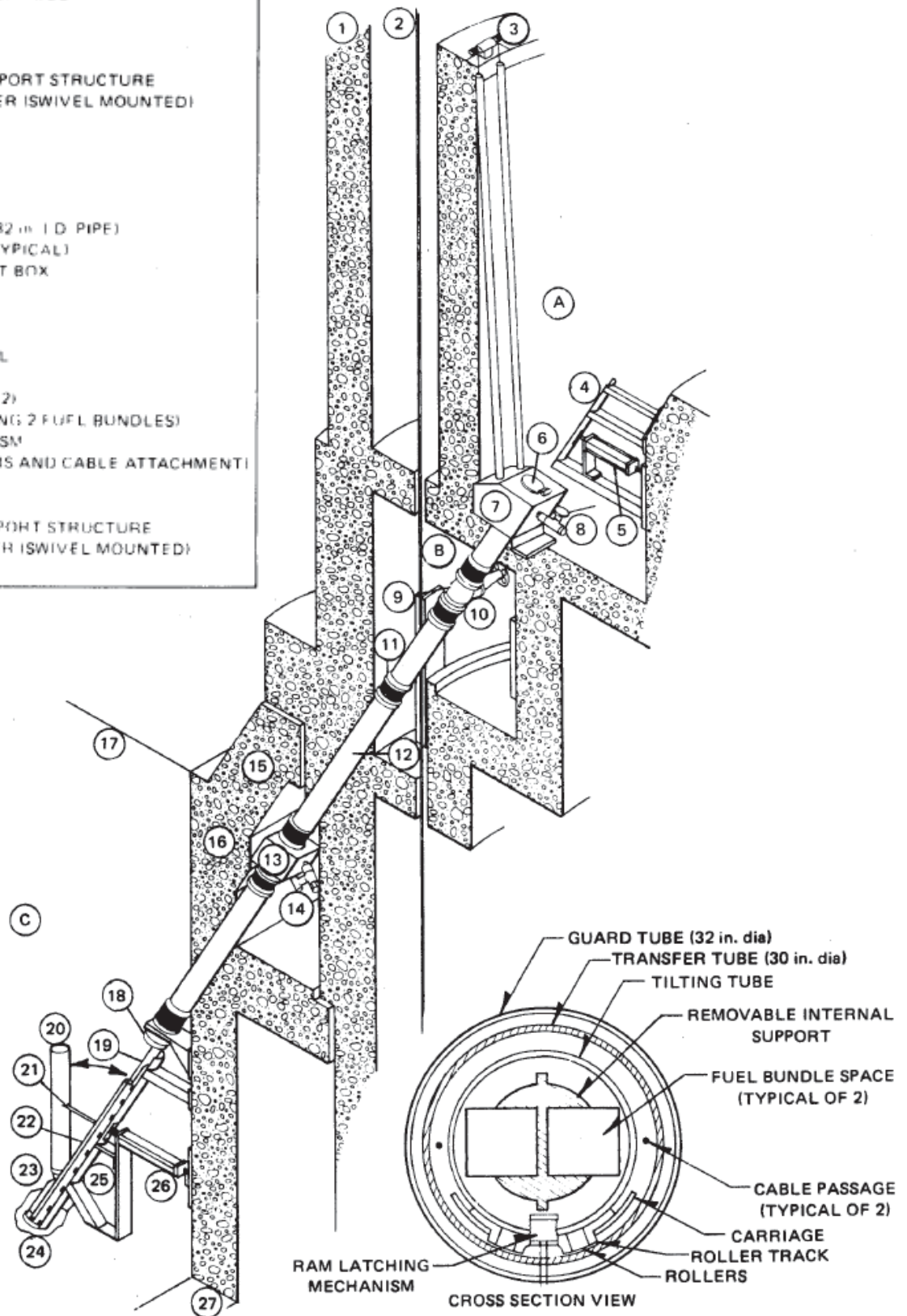

Figure 6.2-11 Mark III Inclined Fuel Transfer System (IFTS)